

Iolo's First book of Crossbows

by David R. Watson



Copyright 1995 - 2009 David R. Watson. All rights reserved. No part of this publication may be reproduced, transmitted, transcribed, stored in a retrieval system, or translated into any language in any form without written permission of the author.

E-mail: info@crossbows.net

URL: <http://crossbows.net>

Published by Gwasg Caeseg Wen Press, 201 West
Crestland Drive, Austin, Texas, 78752, USA.

Foreword.....	1
Parts of the Crossbow	3
Technical Development.....	9
Regional Differences in European Crossbows.....	15
The Stocks	19
Getting What You Want (Replicas and Paraphrases).....	23

Foreword

Welcome to *ILOLO'S FIRST BOOK OF CROSSBOWS*, wherein I will attempt to answer many of the questions I have been asked in the course of making and selling medieval-style crossbows over the last 30 years.

It all began with a Whamo Powermaster my father bought when I was about fourteen and took a leap forward about fourteen years later when I bought a used Powermaster that didn't quite work right. This problematical Powermaster led me to buy Ralph Payne-Gallwey's *The Crossbow, Medieval and Modern* (1903/07), wherein I found out how the Powermaster's previous owner had put the everything out of whack. I started modifying that Powermaster till I concluded it had faults that could not be corrected short of building a new bow. So why not build a neat-o medieval bow? The bow I built in a friend's shop was probably no better than the Powermaster, whose aluminum-alloy prod I purloined, but it looked much neater.

Next I joined a medieval club; all the people thought my bow was pretty neat too. Soon I had enquiries: "Can you show me how to do that?" Eventually, things got out of hand, and I was making crossbows full time. It is difficult to do this on a shoestring if you don't have a spouse with a real job and a shop full of tools. I had a perfectly good spouse and a spare bedroom full of inherited tools, to which I had paid scant attention up to that time.

Fortunately, I received one other thing of value from my father. That was a budding understanding of the axiom which says you can't get anything done without picking up your tools and BEGINNING. No mistake you can make in construction is quite as crippling as the fear of beginning because you might do it wrong. Of course you're going to do it wrong! You have to begin to get anything done, and doing it wrong is a kind of progress in itself. Few mistakes in this craft are irretrievable, but sometimes it's a lot easier to start over.

So just what is a crossbow? It's a short, stiff bow permanently mounted on a stock, that can be spanned and loaded with a projectile, to be released to fly at your leisure, in a controlled direction.

Crossbows are subject to an amazing number of misconceptions. I have been told they are: powerful, accurate, deadly, silent, sinister, underhanded, slow-loading, inaccurate above minimal range, and the ideal poacher's or assassin's weapon.

Most of this is bunk. A crossbow is a bow. Like any bow, it's fairly quiet compared to an Uzi. It shoots little arrows (bolts or quarrels) at a fairly low velocity (typically 150 to 250 feet per second). Crossbow draw weights are often impressively large, but their power-stroke is usually quite short. Medieval crossbows are typically no more powerful than hand bows of about one-third their weight.

Like longbow arrows, crossbow bolts kill (when they do kill) by blood loss, not by hydrostatic shock as a gun does. Crossbows are designed to reduce the variables associated with shooting a hand bow, which makes them inherently more accurate than hand bows, but they pay for this by extra weight, inconvenience, slower-loading and greater cost.

As for being the ideal poachers or assassins' weapon; maybe so, if you can get within about forty yards of your target and are accurate enough to hit THE most vital spot with one shot. Personally, I would not consider shooting a crossbow at anything that might shoot back or report me to the authorities. Crossbows can be deadly and are certainly intimidating, but they're not as decisive as Grandpa Willerson's old Winchester. That's why Grandpa Willerson bought a Winchester, and not a crossbow!

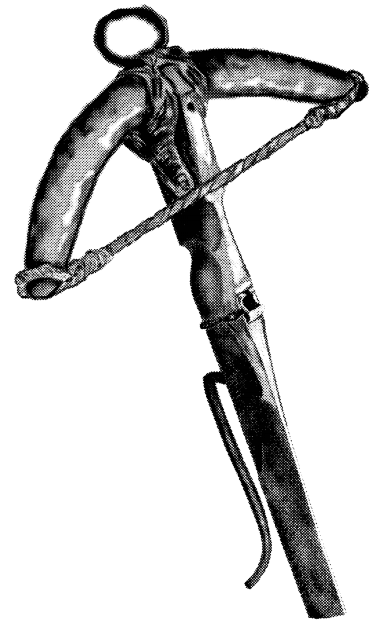

Fifteenth century central European crossbow with a horn-and-sinew prod.

Cutaway Diagram of Crossbow

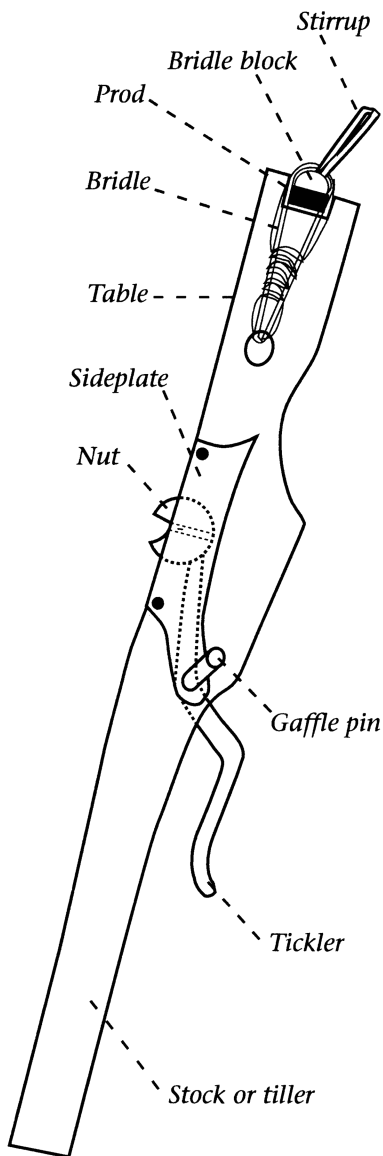

A medieval crossbow looks good on the den wall. Many of my crossbows spend most of their time hanging on someone's wall. Many of them are shot occasionally in the backyard, or at medieval meets. Some work very hard at RenFairs or for shooting fanatics. Others have found their way to regional museums as reproductions for display or demonstration in the hands of docents. These bows are the most demanding work, as museums want their exhibits RIGHT and, while not eager to bankrupt themselves, museum staff are willing to pay what is necessary to get the right goods. I take a lot of pride in the bows that go to museums, but those bows give no more enjoyment than the ones that go to enthusiasts.

Making medieval bows in particular has given me the opportunity to use my training in scholarly research. It allows me to do creative work with my hands, and it has let me peek into the minds and lives of people of a long bygone era, a culture of wood, horn and sinew, as ours is a culture of plastic, concrete and steel. The craftsmen of that bygone age expected reliability, simplicity and permanence instead of novelty, stylishness and planned obsolescence.

Show Robin Hood the accuracy and efficiency of a modern compound bow and he would be impressed. Then might would ask "What if I knock this little pulley off its mount while running through the forest? Into the shop for repair? I think not." For a people on the edge of starvation or oblivion, the little gear they owned had to work. That's part of the charm of the medieval bow, cross or friendly.

It will be apparent that this little book is mostly designed to appeal to the members of medieval clubs, particularly the Society for Creative Anachronism, with which I have been associated for many years. In it I hope to deliver, the sort of information a friend or customer might extract from me over a cold beer at some idyllic campground. I have tried to avoid over-formality: footnotes and bibliographical sources are not rigidly noted, though I hope the references are clear enough to assist others' researches.

So welcome to my little book, done with a great deal of labor, on the part of me, Iolo, my wife, Kathleen (Gwenno), and apprentices great and small. Special thanks to artist James D. Speer who turned my napkin drawings into illustrations, and James Atwood, who converted the format for my web page. If this little volume gives you some pleasure, or teaches you something you didn't know, our time shall not have been wholly wasted.

Iolo, Gwenno, and the apprentices, at various times: Gwenneth, Alasdair, Bevin, Chris, Osprey, Kurt, DW, and Brian.

Parts of the Crossbow

Stirrups

The Stirrup

Spanning stirrups began to appear in illustrations and manuscripts about 1200 AD. Usually it takes a while for these innovations to appear in Medieval documents, so we may take it they came into general use somewhere in the twelfth century, presumably with the adoption of the horn composite bow and belt-claw spanning system.

Generally Central European stirrups are ovoid in shape, while western ones are normally polygonal. I have seen stirrups with studs on the bottom, but long spikes appear to be an invention of the entertainment industry. Renaissance sporting bows that spanned with the gafa or cranequin, sometimes replaced the stirrup with a small hanging ring. By the 16th century a ring or loop was occasionally used as a leverage point for the "wippe" cocking lever.

Stirrups were either bound on with the prod, or fastened on with one of two types of bow-iron mounting. I have never actually seen a medieval crossbow with a bolted on stirrup, though I have made some that way.

Prods and Mountings

Though the few extant Roman illustrations of 'manuballistae' show something resembling a horn composite recurve prod, it is generally assumed that early medieval crossbow prods were of wood, or possibly wood with sinew backing. About 1200 AD, manuscripts begin to describe and show bows with horn/sinew composite prods. These prods appear shorter and fatter than wood bows. Given the presumed extra flexibility and efficiency of the horn/sinew prod, the length of draw may have longer in proportion to the length of the prod.

These stronger, more efficient prods are usually shown with stirrups, and spanned with the belt hook, which would suffice to span a bow of 300 to 440 pounds draw (depending on the type of stirrup and belt claw) at six to seven inches. Horn-sinew prods much in excess of 400 lb. would require a cocking lever, windlass, or cranequin.

Most medieval bows mounted the prod and stirrup by a bridle of hemp or possibly sinew. This mounting is strong, light, and permanent, if somewhat bulky and subject to loosening if it gets really wet. Later medieval bows, particularly western bows, sometimes used one or two wedges, and stirrup 'bow iron' mountings. Bow irons are heavy, but handsome and very strong. Though the wedges occasionally shoot loose, they are easily tightened with a hammer and block of wood.

The steel prod first appears in manuscripts dated about 1330. By 1600, the horn and sinew bow appears to have completely disappeared from inventories. Modern tests have determined that due to their heavy weight, medieval steel bows were only about 40-50% percent efficient. As the price of steel diminished, thanks to the rise of semi-mechanized manufacturing techniques, it became economical to replace expensive horn/sinew bows with cheaper steel bows; first in military bows, and later in gentlemen's bows. Despite their lesser efficiency, steel provided waterproof, low maintenance prods for workaday use. Some sources claim steel was subject to fracture in very cold temperatures, that may be true. Certainly it seems that horn/sinew prods held on longest in cold climates where they could be used year

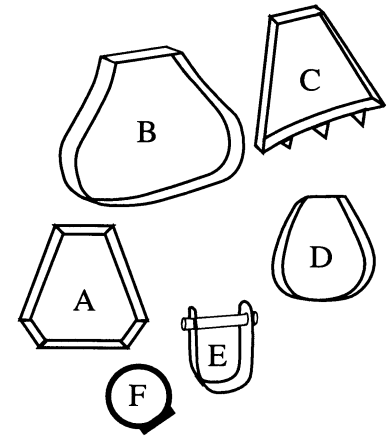

*A and C are western European.
B and D are typical of central Europe.*

E is a pinned on loop for a "wippe."

F is a hanging ring.

Bow Mountings

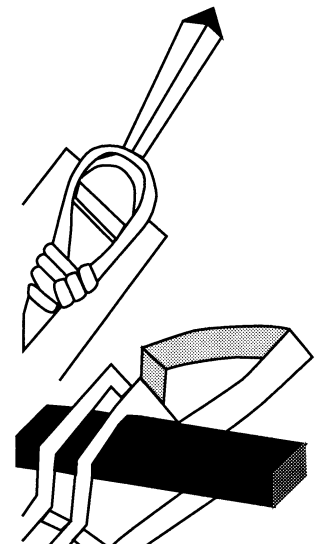

The top mounting is bound in with a "bridle." The bottom schematic shows the bow iron mounting.

Strings

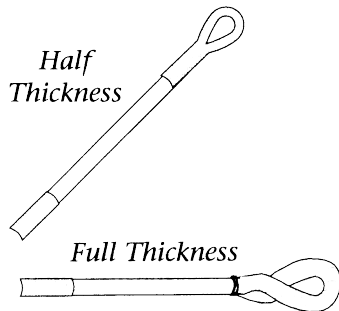

Note that the servings on both ends on center must spiral in the same direction.

Tables

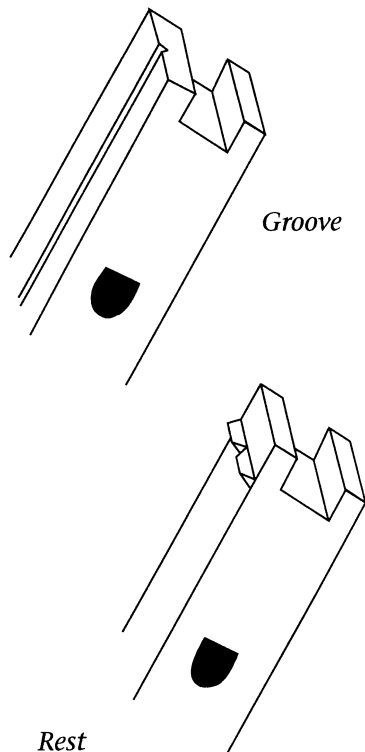

The grooved table (western European) is slightly more reliable. The table with a rest (central European) may have better performance.

'round, despite the weather. (e.g. Switzerland, Scandinavia).

The Bowstring

Extant medieval bowstrings are almost invariably made of hemp (or possibly sinew) and are very thick... commonly as thick as a finger. Most of these bowstrings were heavily waxed, and presumably fairly water resistant, unless really soaked. A hemp string might stretch considerably if extremely wet, and this stretching would affect performance of the bow. A substantial number of extant medieval crossbow strings were made in such a way that the ends of the string were as thick as the center. There are two reliable methods for doing this type of string. Both methods are more complex than a simple continuous loop string, which is only half thickness at the ends. This "knotted" string is much stronger than a continuous loop string. I have long held the opinion that 'single loop' strings found on ancient bows are invariably modern replacements. Recent research suggests I might be wrong about that. (See 'Crossbows in the Royal Netherlands Army Museum' by Sensfelder)

For many years, my bowstrings were made of Tandy's artificial sinew. This heavily waxed nylon compound makes a long-lasting string that looks very much like a waxed hemp string. Artificial Sinew also has a bit of extra stretch, which reduces fatigue stresses to the prod. Over the last few years, I have entirely converted to Dacron B-50 cord, which is commonly used for modern archery. The Dacron lasts longer and gives a quicker throw, though it may reduce the life expectancy of the prod, due to its lack of stretch. I cannot recommend using Kevlar or Fast Flite for my crossbows. Though it shoots even faster, carbon-fiber may shorten bow life even more than B-50.

Top of Stock and Quarrel Groove

Many better quality medieval crossbows covered the top of the stock with horn, bone, or metal, or at least lined the quarrel groove with one of these low friction surfaces. By the 14th century many central European bows dispensed with the quarrel groove entirely, and shot their quarrels off a low bone or horn rest. The rest was permanently placed in cheap bows and adjustable (in a dovetailed slot) for windage in expensive bows. Over many years of practice, I have found that the groove is a little more secure and shows a bit less tendency to misfire than the rest. On the other hand, the rest is subject to more fine tuning than the groove, so may give slightly better accuracy.

For people playing combat games, I recommend the groove. For target shooting, I prefer the rest, though neither of these preferences is very strongly held. Certainly there are western bows with the rest and central bows with the groove.

The Lock

Most extant medieval European crossbows feature the roller nut release with a simple, single axle trigger (tickler). The nut was almost always made of stag horn.

I have found a few examples, mostly of Renaissance bows, with steel or steel-reinforced horn nuts. I know of one example of a brass or bronze nut and one of wood, (though the wooden one didn't fit the bow it was mounted in.) For many years, I put wax-impregnated wood nuts in my cheaper crossbows with good success. They were relatively trouble-free, though they wear out faster than harder

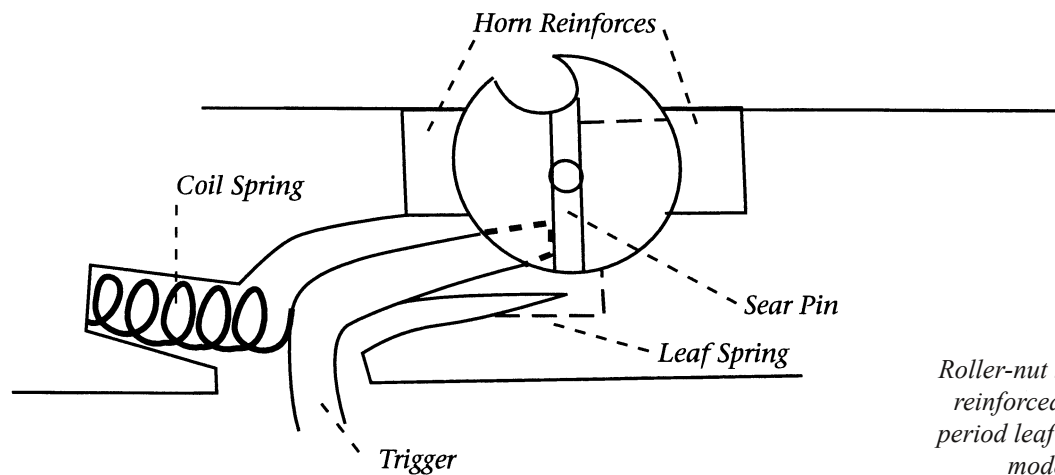

Roller-nut lock showing a horn-reinforced socket and either a period leaf spring or convenient modern coil spring

and more resilient materials. About 1 percent of wood nuts crack or break. I do not recommend them over about eighty pounds of draw, though I've seen oak used successfully for thousands of shots at over 120 pounds.

Some years ago, I began experimenting with industrial plastics, particularly Delrin and Hydrex, for roller nuts. Delrin in particular has become a favorite. It's strong, self-lubricating, and can pass for horn from a yard away. Nowadays, all my standard bows, up to 150 lb. or so, get Delrin rollers, it's that much better. I only do wood nuts on special order.

Brass or bronze nuts are pretty and strong, though heavy and slow to release. These nuts sometimes tend to misfire due to their slow rotation, and they waste a certain amount of power due to their high mass and consequent inertia. They last effectively forever and require very little maintenance. Given the excellent alternatives available, I try to discourage anyone installing a brass roller.

Horn nuts are strong, fast, and light. They last a very long time and probably constituted 90 percent of medieval locks. Due to their resilience, they sometimes rebound in a loose socket on release, and crack the back of the nut socket. Sockets for horn nuts can be fitted with a reinforcement of horn or metal behind the nut to prevent this problem. Many medieval bows reinforced the socket at front and back with blocks of horn. The stag horn necessary for horn nuts is expensive, and stinks when you cut or turn it.

Steel nuts are expensive and time-consuming to make. (Don't bother to ask me, I won't make you a steel one, neither of us can afford the time and money.) They are faster than brass, though slower than horn. They last for ever and are excellent for very strong bows. With very strong bows, they should be used with a reinforced socket.

The Socket

The nut socket is usually 3/5 to 2/3 of a cylinder, cut into the stock. The roller-nut runs in this socket and fits closely, but turns easily. More powerful bows will usually have the front and back edges of the socket reinforced with horn or metal blocks. Central European bows often had the nut and socket made separately and the socket glued and pinned into a rectangular mortise cut into the top of the stock. Some western bows mortised their locks from the top, but others had the socket cut through the side of the stock. Strong metal side plates, fitted with small metal pins, reinforced the socket's sides and kept the nut in place.

Morticed Lock

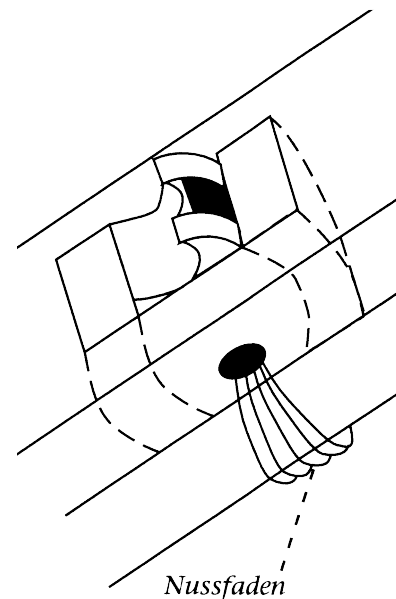

Morticed lock made as a unit and installed in a rectangular socket cut in the top of the stock.

Complex Locks

Two-axle lock
1450 – 1500

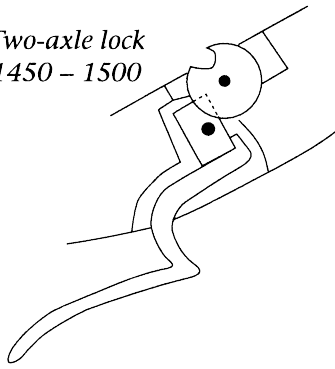

Clap lock
circa 1550
onward

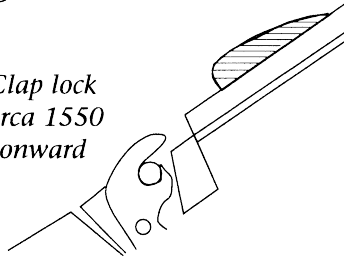

Multi-axle
lock 1500
onward

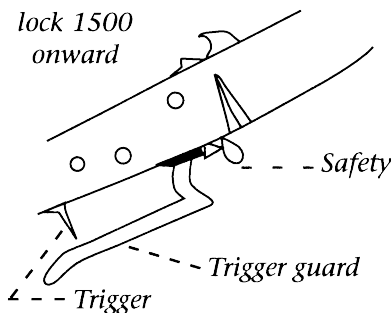

Three complex sporting locks that
increase accuracy.

Trigger Shapes

Western
European

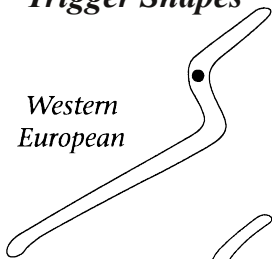

Central
European

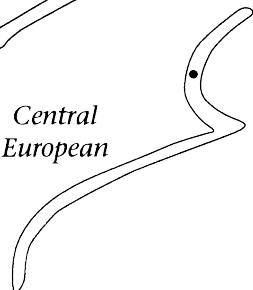

Shapes vary substantially by time
and place.

In central European bows, the fit of the nut was not quite so close, and the nut was held in place by a heavy cord binding (nussfaden) that prevented the nut from oscillating or hopping out after release. It is often difficult, from first appearances, to tell if a bow is made with the side-cut or top-mortised lock, since side plates of metal or horn were commonly used on both types of bow.

Self-setting Locks

I have seen one example of a self-setting lock on a Renaissance crossbow. It was a bit complex, but looked pretty workable. Some years ago SCA shooters experienced a fad for self-stopping or self setting locks, in search of faster rates of fire. In point of fact, medieval crossbows were not optimized for quick shooting. Due to the demand, I experimented with self-stopping locks, but found that short of making the fully realized, complex self-stopping lock, shown in Paterson (P. 100), self-stopping locks are workable only on very light bows of fifty pounds or so.

Even such bows have a tendency to destroy their locks in the first few thousand shots. Some shooters manage to effect a self-stopping, or self-resetting, lock by timing the release of the trigger to stop the nut by popping the end of the trigger into the sear as the roller finishes its first rotation. The trick works tolerably well on a bow of moderate power, but it may result in excessive wear of the sear, trigger, and trigger bolt. If you insist that the trigger do the work of a stop for a nut spinning at great speed, don't be surprised if the parts wear a bit faster than anticipated.

The Trigger

There are perhaps three extant stone engravings of Roman 'manubalista' crossbows, and at least one bone roller nut from the 8th century. That's not much to go on, but it appears they used some sort of roller-nut, possibly with a bone or wooden trigger.

There are a few extant illustrations from the 11th and 12th centuries which may show either roller nut releases or primitive notch and peg type locks. Again it's hard to tell from very primitive illustrations. It is possible to say from later illustrations that many (possibly most) European crossbows of the later middle-ages released via a long "tickler" trigger, working directly on the roller nut. The lock trigger was more or less as illustrated, fitting into a metal-lined notch (sear) in the bottom of the nut. Normally the trigger was assisted in locking into the sear by a leaf spring of horn or steel. I usually use a coil spring in a pocket, as it's easier to construct that way and more reliable than a leaf spring. I have seen one example of a Spanish light military or sporting bow which may have used a sliding wedge to set the trigger in the sear and incidentally serve as a safety.

Between 1450 and 1500 a slightly more complex two axle lock was put into some sporting bows. It allowed a crisper, easier trigger pull for accurate shooting, at the cost of a little bit of speed in loading. In the 16th century the central European clap-lock made its appearance. This lock was suitable for bows of moderate power and probably cheaper than the successor to the two axle lock, the multi-axle lock. Clap-locks place the butt of the quarrel about one quarter inch ahead of the string in a small groove (a steel spring-clip holds the bolt in place). On release, the string actually strikes the butt of the quarrel, sending it downrange. Personally, I have never been too crazy about this "slap" feature, but the clap lock saw service for many years on some pretty expensive bows, so it must have done good service.

By the 16th century almost all extant powerful sporting bows used the multi-axle roller-nut lock that released with a small gun type trigger. Most of these bows retained a trigger guard that looks like the long tickler trigger of the one- and two-axle locks. The only way to tell for sure is to peep beneath the apparent tickler for evidence of a small vertical trigger. Look closely they usually fold up, out of the way. These bows usually show the ends of three or four pins along the side of the stock, another fair indicator of a multi-axle lock.

Long ticker triggers vary distinctly in shape, according to period and geographical location, but they fall into two distinct categories. Western bows usually had a rounded angle at the first bend in the trigger (after it left the bottom of the stock). Central European bows usually had an acute angle in the trigger at this point and a slight curl in the very end of the trigger, whereas Western bows were sometimes without the end curl.

For what it's worth, I have found the acute angle in the trigger makes a handy grip or hanging point for an unspanned bow. In most cases, the trigger extends almost to the end of the stock, as strong bows required plenty of leverage for release. In period illustrations, all but the largest crossbows are shown held free of the body, with the butt of the stock alongside the cheek, very much like a hand-bowman drawing an arrow. Most of my bows use a rather shorter trigger, as their light draw does not require great leverage. Most modern shooters prefer to rest the butt against their shoulder, and long triggers may constitute something of a safety hazard for people not accustomed to them.

Crossbow Butts

The few extant examples of Roman and post Roman crossbows show a butt consisting of a short, lathe-turned cylindrical handle with a small flange or knob on the end. Illustrations from the twelfth century and later, show a long, narrow tail, perhaps as small as one- to one-and one-half inches square. A few have a ball or scroll at the end.

By the 16th century, some sporting bows, particularly those with cheek pieces, featured some slight enlargement of the butt, though it appears these bows were not generally held against the shoulder. By the 17th century German clap-lock crossbows had real enlarged butts to rest atop the shoulder (or possibly against the breast), like the firearms of the day. The actual flask or musket-butt commonly used on modern crossbows only appeared in the early 18th century.

Projectiles

Most period crossbows shot bolts or quarrels of hardwood, with iron or steel points. There are some references to all steel or iron bolts for very heavy crossbows in the 16th century. Most extant medieval quarrels range from twelve to eighteen inches in length (average about fifteen inches), and where the fletching survives, they are usually fitted with two vanes directly opposite one-another, which may or may not be arranged to induce spin. The fletching on period bolts might be of wood, parchment, leather, feathers or metal. Some bolts had no fletching at all. Mostly what survives in museums is fletching of wood, in the form of thin, flexible vanes 4-5 inches long, glued into slots in the sides of the bolts. Occasionally the vanes are of one piece with the shaft.

Better quality bolts were sometimes barreled or tapered to improve aerodynamic

Butt Shapes

Roman 3rd or 4th century AD

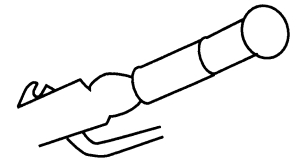

15th or 16th century central European



17th century central European



18th century western European "musket butt"

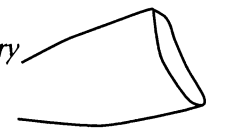

Note that Roman and Renaissance butts are held against the cheek; 17th and 18th century butts are held against the shoulder.



Sixteenth century German sporting bow with enlarged butt.

Military Points



*Mary Rose point
(quarrel point with barbs)*



Forked point



Small broadhead



Quarrel point



Medium bodkin



Harness point

form and stability for better flight. The best quarrels were generally considered to be those made of heavy, resilient wood, like ash and birch. The noted Elizabethan archer Roger Ascham expressed a distaste for lighter arrow-materials, like poplar, primarily because softwood shafts broke easily against a hard target, and retained less energy at long range than heavier ones. Some modern fletchers have found that poplar, in particular, makes a very nice material for modern recreational quarrels.

I have never seen a period bolt with a butt cap or a nock at the rear, but that doesn't prove much. Some bolts perform better if their butts are made slightly hollow, top to bottom.

Points

Medieval shooters enjoyed a large variety of points for both hunting and war. Most period illustrations show crossbow bolts stored point in the quiver, presumably to make point selection easy. Many quivers had top flaps to prevent sharp points gouging the hand.

The most common varieties for sport are:

1. Broadheads, with or without barbs.
2. Forked or chisel points, used for shooting large game birds.
3. Solid wood blunts for birds or small game.
4. The metal headed blunts, for the large wooden 'Dresden Bird,' placed atop a tall pole.

Military points might include:

1. Broadheads, usually barbed, for use against unarmored targets.
2. Leaf bladed, diamond section "quarrel" points, with or without barbs, for lightly armored targets.
3. Forked or chisel points, used at sea to fire into the rigging of enemy ships.
4. Long square- or triangle- section bodkin points for breaking and piercing mail.
5. Shorter bodkin points- less effective against mail, but easier to affix to the shaft and actually more effective against light plate armor.
6. Harness bolts: very short bodkins of the best quality steel, for use against plate armor. These bolts were made as sharp as practicable, but had a blunter angle at the head than the needle-pointed bodkin. The very narrow bodkin could break or bend when striking an oblique angle.

Remember that arrows do most of their damage by cutting muscle and ligaments and by bleeding. The best point to use against game or an enemy was the one that promised the greatest tissue damage. Armor protected a warrior in two ways. First, it stopped or deflected many strikes. Second, it ensured that any projectile that defeated the armor would be less than ideal as a wounding instrument.

TECHNICAL DEVELOPMENT

I usually begin any discussion of European crossbows with the Roman “manubalista.” It is predated by the Greek “gastraphetes,” but the details of the gastraphetes construction, lock and size make it a primitive catapult. The Roman manubalista was the first European crossbow that really served as an individual weapon for hunt or war.

There are a few documentary references to manubalistae in the hands of Roman Auxiliary troops and three or four stone engravings of the bows themselves. The illustrations show two types. One is apparently a light hunting bow, shown en-suite with a basket-work quiver, narrow bolts, and small game: birds and rabbits. The other bow is a more robust weapon, depicted in a military procession. Both bows feature a recurved prod, and a short stock, somewhat enlarged at the front. One illustration clearly shows a quarrel groove and a lock that may be a roller-nut. These particulars, coupled with crossbow parts from 8th and 9th century grave finds in Britain (e.g. the Buston-Crannog find in Scotland), suggest the bow illustrated: with a short stock ending just behind the lock and extended by a turned bone or wooden handle. The lock appears to be a precursor to the later roller nut release. What details this bow might have had: carving, inlay, trigger mechanism, etc. are moot, though a very wide sear on the nut of the Buston-Crannog bow may point toward a wooden or bone trigger. Until somebody comes up with a preserved stock, the details of manubalistae are anybody's guess.

There are a scattering of surviving literary references to crossbows from the 10th and 11th centuries. The few simple drawings from the era suggest a short stock, perhaps twenty-five to twenty-eight inches in length. In most cases, the bow-stave (prod) appears long in proportion to the stock and is presumably of wood, possibly reinforced with a sinew backing. Both roller locks and a drop-pin lock appear to be in evidence, usually situated at mid-length. When spanning these bows is depicted, the Bowman is shown with his feet against the prod. The later spanning stirrup is not in evidence. Some stocks show extra depth at the head, and in one illustration there is clearly extra wood around the lock and a short Roman style butt with a ball end. There is little evidence as to how the prod was fastened in, though at least one illustration features a few hash-marks that might indicate a rope-binding. Long triggers are in evidence, departing from the stock at a substantial angle.

As with Roman bows, any attempt at replication is doomed to produce a very generic product. We must speculate based on very simple sketches. Decoration is unknown, dimensions may be estimated by comparison with human figures. Shooting power would presumably be limited by the strength of the shooter's hands, since spanning appears to be entirely manual.

About the 12th century the European crossbow underwent a great change, possibly due to the First Crusade. These changes appear in records and illustrations about the beginning of the 13th century. City and court records begin to talk of “crossbows of one and two feet” and “crossbows of horn.” At the same time, illustrations begin to show longer stocks fitted with short, fat prods, and spanning-stirrups.

The reference to bows of one or two feet may refer to ordinary field bows (one foot) and siege bows (two feet). Both types were spanned by means of a heavy hook suspended from the shooter's belt. With the one-foot bow, the shooter put the hook on the bowstring and pushed the bow down with one foot (in the stirrup) till the string could be placed in the lock. Two foot bows required a stirrup large enough for both feet. The shooter either crouched and hooked the string, or sat down and put

A Roman Crossbow

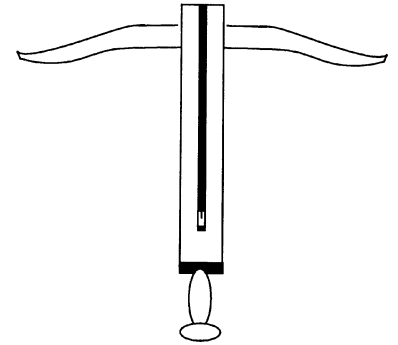

Detail from a Roman grave marker circa 400AD, Polignac-sur-Loire, France. After H. L. Blackmore

Spanning

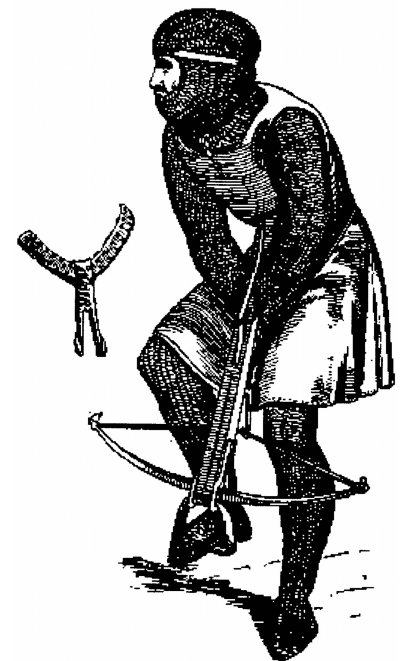

Man spanning a crossbow with a two-clawed belt hook (after Viollet-le-Duc).

Finnish Crossbow

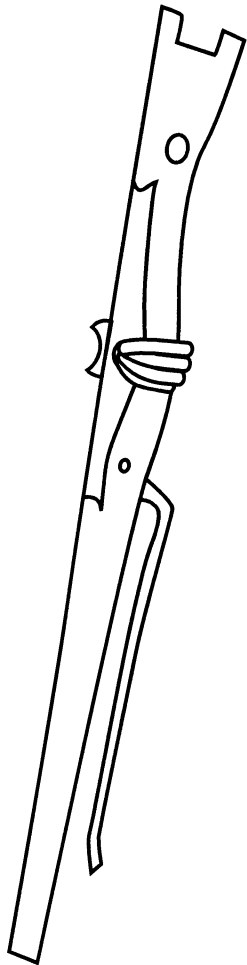

An Example of the emerging pattern of bows used with the belt hook.

both feet in the stirrup. Then he pushed the bow away with both legs. This new bow is the horn composite bow of the high Middle Ages and may be the weapon which caused the Second Lateran council (1139) to pronounce against the use of the crossbow against Christians.

Modern experiments suggest that one-foot bows might draw up to 150 kilograms and two foot-bows as much as 200 kg. Illustrations show stocks longer than on earlier bows, perhaps thirty to thirty four inches in length. My experience suggests that very short stocks are difficult to handle when spanning with the hook. Although the new stocks were longer, the length of draw increased little if any, as the lock now appears about one third of the stock length from the front. The first stirrup bows, based on a few manuscript pictures, may not have looked very different from the oldest extant 14th century European bows. (Much like my model 5F)

Horn-Sinew Prods

The horn composite prod was a complex construction, composed of a horn belly (in compression) and sinew back (in tension) that made maximum use of its components to produce a very light (if bulky) prod of great power and efficiency. These bows were expensive to make, and subject to degradation of performance if really wet, but some sources suggest they actually got stronger in subzero weather. The great strength and efficiency of the horn bow allowed a stronger, lighter, shorter bow stave to be pulled as far as the old wooden prod and gave higher velocity to a heavier projectile. The horn-composite crossbow was the most efficient projectile weapon on the battlefield for about a century, but due to the greater expense, it never succeeded in replacing the older wooden bow.

The end of the 13th century saw the introduction of the Anglo-Welsh longbow in large numbers. The Longbow proved its supremacy at the battle of Crecy (1346) and became the northern European battlefield bow of choice until the middle of the 15th century. Longbows drawing 100 to 180 pounds were capable of very rapid shooting in the hands of an expert: perhaps as many as twenty shots a minute, for short flurries. Estimates of the English arrow supply at the battle of Agincourt suggest 600,000 arrows for perhaps 9,000 archers. That's less than 70 per archer: contemporary accounts suggest they shot them all. Experienced archers of either sort could engage large groups of people at 250 yards, and would have a reasonable chance of picking out individual targets at 100 yards.

The best longbows were made of carefully selected central European mountain-grown yew. It's likely these bows produced greater power and range than most military crossbows of the 14th century, with the possible exception of the large, two foot siege bows. Although the draw weights of typical longbows were less than half those of contemporary crossbows, their power stroke was perhaps three times as long.

Modern tests of reproduction longbows suggest they were 65 to 75 percent efficient with heavy military arrows. Comparing crossbow and longbow power is a tricky business at best, with many factors to consider. To get a reasonable rule-of-thumb calculation of the power produced by a longbow of 100 pounds at twenty inches of power stroke (this does not count the brace height of seven to eight inches only the active power stroke) we multiply the weight, 100 pounds, by the draw (twenty inches) and by the efficiency (70 percent) to get 1400 inch-pounds. A 300 pound one-foot crossbow drawn six inches at a very-high 75 percent efficiency produces a figure of 1350. (Note this is a comparative figure only, not an engineering value. For accurate calculation, you need to know the actual movement

of the bow limbs, generally about one- third of string movement.) The crossbow's bolt may be slightly more aerodynamic than the longbow arrow: some were, but being shorter, the bolt is less stable in flight. So we expect the relatively light 100-pound longbow (based on calculated bow strengths from bows recovered from the ship Mary Rose, @ 1545) to produce slightly more power than a near-maximum one-foot field crossbow. Given that the crossbow might deliver a maximum of four or five shots a minute, it's pretty obvious why Genoese crossbow men were blown off the field by longbows at Crecy, without any of the contemporary excuses about bad weather and wet bowstrings. Face it lads, you just got beat!

So why didn't the longbow completely replace the crossbow? Though longbows were vastly cheaper to buy than crossbows, they required very fit and well-trained archers to be effective. A good longbow man, age twenty-two, had practiced regularly from age seven. That represents a huge investment in training. The crossbow, with its prod held fast in the stock, a secure and consistent lock, and a solid stock to brace against the body, reduced the variables of shooting, and shortened the training time to perhaps 10 to 20 percent of that required for the longbow. This made the crossbow ideal for use by wealthier town militias. There was an added advantage that the less-intense training schedule for crossbowmen meant the weapons could remain in the city armory, instead of residing in the homes of the militiamen. Thus, the authorities could control the supply of deadly weapons in times of civil strife. A fear of revolt home seems to have been one of the reasons for the failure of French militias to make a go of their efforts to train longbow men.

In southern Europe, higher temperatures in summer campaigning season seriously effected the efficiency of the yew longbow. According to one authority, For every degree of temperature over 70 degrees (Fahrenheit), a yew longbow loses one-percent of efficiency. In southern Europe, recurved horn-sinew hand bows, like the Turkish bow as well as various crossbows remained popular battlefield bows for most applications. Crossbows also held on in northern Europe for hunting and the sniping work of siege craft. They could be shot very accurately from hidden or cramped positions, even by semi-trained archers, under conditions where rate of fire didn't matter very much.

The response of crossbow makers to the longbow was to develop machines that could span much heavier crossbows than could be worked by hooks or belts. Some of the new crossbows used cocking levers, which only slightly reduced rate of fire, but the strongest crossbows used the rack and pinion cranequin or the large compound-pulley windlass. These machines slashed the rate of fire to only one or two shots a minute. Given their slow loading, these new crossbows were unlikely to replace the longbow in the field, though they could penetrate much of the heavier plate armor which was necessitated by the advent of massed longbow men. Yeah, these questions get very involved, don't they? Rock-paper-scissors.

About the mid 14th century, surviving literature indicates an increasing numbers of steel prods for crossbows. The new prods were actually less efficient (40-50 percent) than horn composite bows, but were becoming substantially less expensive to make as steel manufacture became more mechanized and specialist bow smiths became commonplace. Since the latest and strongest horn bows required a machine to span anyway, it was simple enough to adopt a still heavier spanning machine and a much heavier steel prod. Many of the better quality gentlemen's crossbows continued to be made as horn-sinew composites, at least to the end of the 15th century. For military purposes, the steel prod was affordable, mostly weatherproof, and required very little maintenance. Steel bows were much heavier to carry of course, but that's no problem for the purchasing agents and generals.

Prod Cross Sections

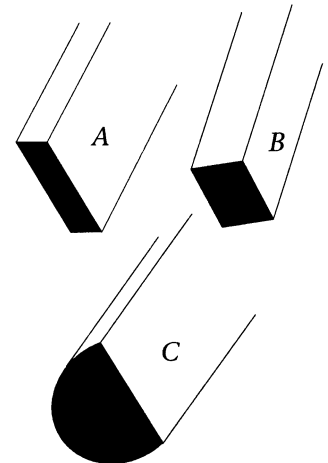

A is a central European steel prod. B is a Spanish steel prod. C is a horn and sinew prod.

Cocking Machines

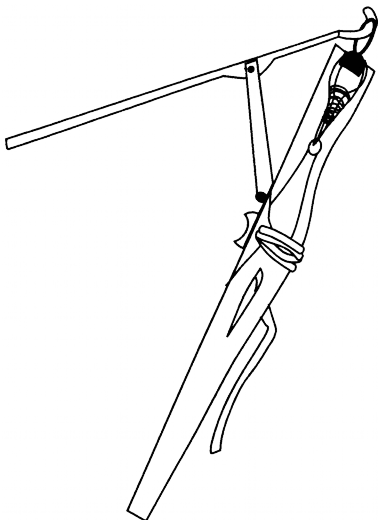

Wippe

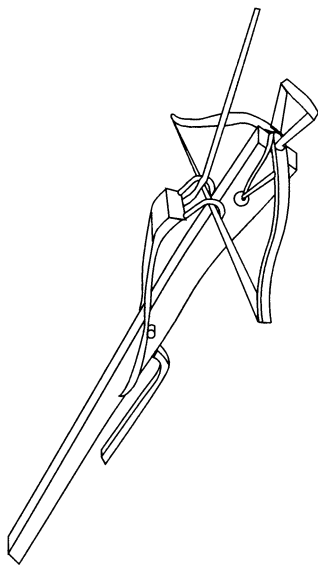

Goatsfoot or gaffe

The Wippe (top) is a robust, inexpensive, central European cocking lever. The Goatsfoot (bottom) is a more efficient and expensive western European lever.

You can always tell the steel prods from the horn composites in museums. Composites are shaped like slightly flattened sausage, whereas steel ones are mostly rectangular (I know of one diamond-shaped steel prod). Interestingly, Spanish steel prods are usually narrower and thicker than, say, German or Italian steel prods. Often the draw appears a bit longer as well. I suspect this is due to superior Spanish steel, thanks in part to their iron ore that naturally bears traces of the elements that make efficient alloy steels, as well as an ancient tradition in steel production.

By the 15th century German crossbows were divided into categories of full, half, quarter, and “schnepfer” bows. Full bows: five or six feet in length and span, were siege machines that might draw 2000 pounds and shoot five-ounce bolt 450 yards. Such a piece could weigh twenty pounds or more.

Half-bows were standard military and hunting bows, weighting ten to twelve pounds. They might draw as much as 1000 pounds at six inches and shoot a three-ounce bolt 350 yards. Both full and half bows were commonly spanned with the compact and powerful cranequin. This rack-and-pinion machine was easy to use, but expensive to build and rather slow to load, at about one shot a minute. A quarter bow would be slightly slimmer than a half bow. Their bolts might be two to two-and-one-half ounces and shoot 250 to 300 yards. Most of my bows are about the size of quarter bows. They weigh six to eight pounds.

Schnepfers were light hunting and target bows. Some were made to shoot bolts, others were built to shoot only baked clay pellets. They served about the same purpose as .22's or pellet guns. We might call them “plinkers.”

Spanning Machines

Some quarter bows were drawn with the cranequin, but others were spanned with the western “gafa” lever or the simpler, less expensive and less efficient “wippe” cocking lever. In my experience, the gafa, or goatsfoot lever is much more efficient than the wippe, as well as quicker and easier to use. Unfortunately, the gafa, as excellent as it is, requires the services of a competent smith to build, whereas the wippe can be made by any competent woodworker.

Decreased cost and ease of construction probably explains the continued popularity of a cocking system that is to my mind inferior in every way to the gafa. Now don't get me wrong, the wippe will cock a strong bow just fine, given sufficient size and a bit more time to load, but I certainly don't think the wippe would offer any challenge in military service to the gafa. I think an experienced shooter might be able to load four to six shots a minute with gafa, though service rate of fire would, of course, be less, because one has to locate a suitable target to shoot after loading. In a mass assault, this might be an easy task, but sometimes an archer might have to pick shots with care. The wippe lever requires more time to position and operate, so its loading speed might be twenty to thirty percent slower than the gafa.

In western Europe, military crossbows were organized in three categories. Gafa or goatsfoot bows were the lightest, used by light infantry and cavalry. They were quick to load, very handy, and probably had about as much power as a central European quarter bow. Middle-sized 'half' bows commonly used the cranequin, or 'cric', and the heaviest bows were “Arabalet a Tour,” using the unwieldy “English” windlass with its ropes and pulleys, that mounted on the butt of the stock for spanning.

My experience with the windlass suggests Ralph Payne-Gallwey's estimation of one shot a minute is rather too low. I think two could be achieved with very little

practice. The bows using the windlass were likely heavy infantry and siege bows. The central European cranequin was used on some medium-weight bows, in Western Europe, probably for both infantry and cavalry, as it was easily manipulated on horseback or in cramped positions, though perhaps a bit slower loading than the great windlass, and substantially slower than the gafa. Payne-Gallwey suggests two shots in three minutes. My limited experience with the cranequin suggests a shooting rate of about one a minute, though gear ratios varied considerably from machine to machine. Some central European siege bows may well have used the windlass, but there are some examples of large siege bows made to use the cranequin as well.

The late 15th century saw the arrival of numerous and efficient firearms on the battlefield. These weapons, whose numbers had been growing noisily since the battle of Crecy, had reached a point at which the lighter artillery was fairly mobile, and individual hand-held were strong and reliable enough to be effective in the field as well as in siege. The subject of fire arms in the Middle Ages and Renaissance is one in which there is much ill-informed and semi-informed opinion, and I am eager to record mine.

Some modern authors deplore medieval firearms, calling them ill-conceived and more dangerous to the shooter than the target. To me it seems unlikely that medieval firearms would have been employed under such circumstances. To some extent, guns may have been employed as terror weapons for the effect of their loud report on horses and men and for the fact that smoke may obscure targets and movement. Some archery apologists have asserted that bows were more powerful, based on their greater penetration of, say, wood, at 100 yards. The flaw in such an argument is obvious: arrows are sharp, pointy, and heavy. They are designed to penetrate, and most of their damage is by cutting and bleeding. Bullets were usually spherical and were lighter and flew much faster. They did their damage as much by shock, destroying tissue by hydrostatic action, as by cutting. They were not expected to penetrate deeply into a wooden target, which was just fine, because the enemy were not generally made of wood anyhow.

Guns vs. Bows

Given the difficulty of observing the flight of a bullet, as compared to an arrow, and the relatively higher velocity of a bullet (say, 500 feet/second, instead of 220 ft/sec for a pretty fast arrow), firearms were generally employed at fairly close ranges, say, 100 yards or less. The shooting rate for firearms was usually rather slower than even the heavy crossbows. (Probably less than one shot a minute under good conditions.) In short, the gun's advantages included:

1. Hand guns were fairly cheap to make, though somewhat expensive to shoot.
2. Like crossbow men, gunners were easily trained.
3. Gunners did not consume the masses of first class rations required by longbow men.
4. Projectiles were easily made (though gunpowder was not), and handgun ammunition was quite compact and easily transported, as long as the powder was corned arquebus powder, and not the cheaper sort of meal-powder.
5. The report and smoke of guns was generally assumed to be intimidating as well as obscuring movement.
6. A volley of firearms delivered at short range could do more damage to enemy formations than several from a like number of bowmen.

Cocking Machines

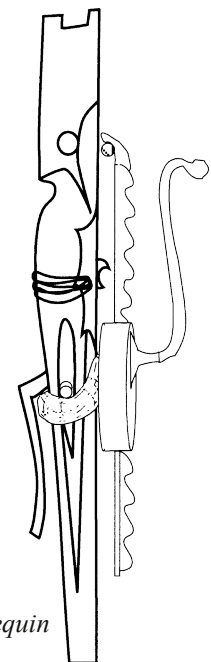
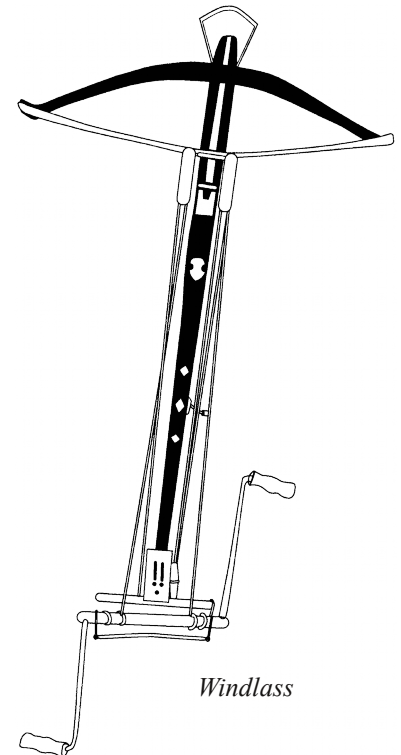

More sophisticated, expensive, and slow-loading are the windlass and the cranequin.

7. Firearms were modern and trendy.

On the negative side, firearms were less accurate at longer ranges, slow to load, and lots of trouble in wet weather. Gunpowder was expensive, difficult to keep dry, and, in the case of the cheaper variety of powder, subject to separation into its chemical components when transported over long distances, which made it effectively useless until remixed.

Whatever the virtues and vices of the weapons, by 1500 most armies and militias were replacing their longbows and crossbows with firearms, though the English officially held on to the longbow until the 1580's. Many crossbows found continued employment in the suppression of “primitive” (read less militarily advanced) peoples and at sea, where ranges were short, enemies seldom well armored, and the danger of fire from guns in the rigging was a very serious concern.

Despite the steady growth of firearms, the sporting crossbow continued to thrive in Europe; in some places well into the 18th century. By the mid-16th century, sophisticated, very accurate target and hunting crossbows were wide-spread. The survivors of these bows show complex locks, adjustable sights, and ornate decoration. In this period, the work of crossbow maker and gunsmith began to grow together, and where early gun stocks were often made by crossbow makers and looked like crossbow stocks, now crossbow stocks were often made by gun makers and looked it. By the early 17th century crossbows actually began to develop something like an enlarged gun butt, though the classic musket or shotgun butt we're accustomed to didn't appear until the 18th century. The last really popular crossbows: stone bows or bullet bows, were widely used for small game hunting, smashing windows, and general mischief, much like modern .22's or pellet guns. Their popularity suddenly ended @ 1860, with the introduction of .22 rim fire cartridge guns, which were more accurate, yet cheap to shoot. Today the crossbow is enjoying a substantial revival. Many of the modern crossbows on the market are exceptional tributes to the efficiency of our manufacturing systems, if you consider their relatively high quality coupled with low price. Some of them even shoot well.

REGIONAL DIFFERENCES IN EUROPEAN CROSSBOWS

Typical Western European Stock

Regional differences in fifteenth and sixteenth century crossbows show two distinctively different types with many variations within types and a bit of blurring on the edges.

We can roughly divide European crossbow stocks into two categories: Ovoid cross section central European bows and rectangular section western European bows. It would be futile to try to assign a qualitative value to either type, as they have their own individual strengths and weaknesses. I personally find the central bows rather prettier; though the angular Flemish arbalest, in particular, seems somehow quintessentially medieval, a bow from a different culture with different aesthetic standards.

Western European Stocks

Generally speaking, western stocks are relatively narrow and flat-sided. Their appearance is angular and purposeful. They usually use the plainest roller-nut release and push their bolts down the stock in a plain groove in the top (table) of the stock (lined with bone or horn in better-quality pieces). They will be spanned by the goatsfoot (gaffe or gafa) cocking lever, or perhaps by the “English” windlass, or long “Spanish” cranequin. Many western bows fastened the prod with the stirrup and wedges of the “bow iron” mounting system, which is less common on central European bows. Though stock shapes vary, the sides are usually more or less parallel from the head to a bit behind the lock, and the stock will be taller about the prod mounting and usually at the lock as well. There are western stocks that taper in width from lock to head and are not taller at the lock. Some western bows bear ornate, usually geometric inlays on the stock.

Spanish bows are usually straight, plain and slender. Italian bows often show a strong Spanish influence. Extant English bows often look like Spanish or Flemish pieces, as successive English monarchs tried to limit the use of crossbows to the wealthy and to foreign mercenaries, so that the people might become accustomed to shooting the bare military longbow. English crossbow makers must have been as rare a breed as Arthurian shrubbers.

Central European Stocks

Central and Eastern European crossbows commonly feature a round or oval cross-section. They usually show few unbeveled edges and the sides of the stock are typically rounded like a barrel, though very wide half bows often had a substantial flat on top and bottom. It is common for central bows to be widest at the lock, and taper gently both fore and aft, though this is more pronounced in bows that use the cranequin for spanning. The shorter variety of cranequin bow is often quite tubby at the lock. The cranequin usually requires a lug or pin that transfixes the stock from side to side; about six to ten inches behind the lock. If the transfixing pin is only two to three inches behind the lock, it is for the gafa lever. Some lighter Central European bows were spanned with the wooden “wippe” lever, and will be fitted either with lugs just behind the prod, or a simple loop riveted to the fore-end, just above the prod.

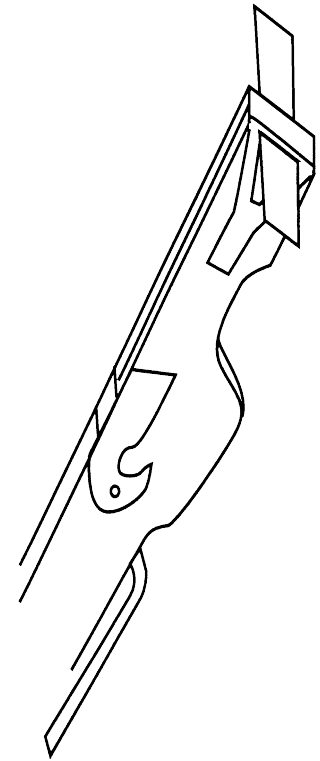

This 15th to 16th century Flemish bow has an arrow groove, flat, parallel side, bow irons, and a trigger with rounded angles. The through-drilled lock has heavy steel sideplates.

Central European Bow Cross Section

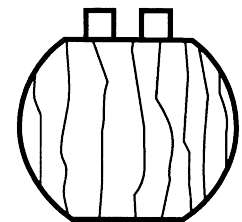

A cross section, just behind the lock, shows the rounded lines typical of a central European crossbow.

Typical Central European Bow

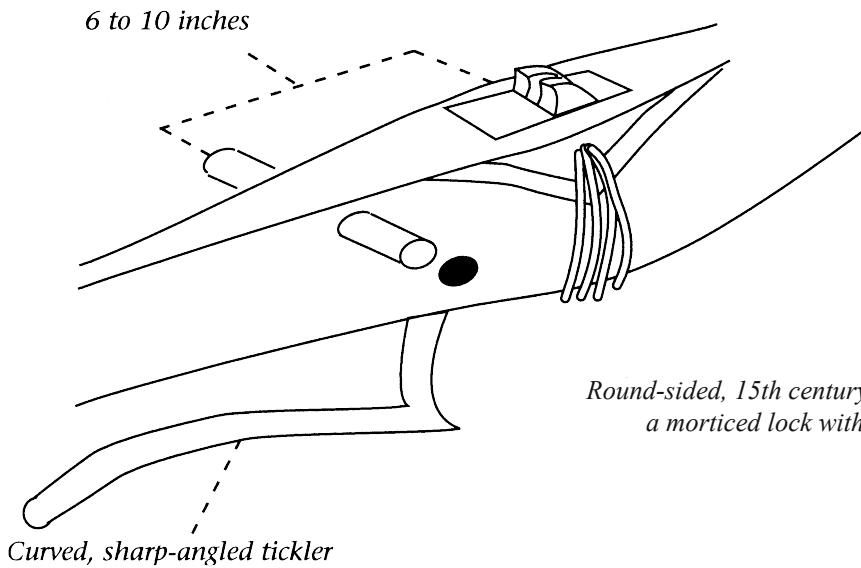

Round-sided, 15th century central European bow shows pins for cranequin, and a morticed lock with small horn sideplates to reinforce the nussfaden

A large proportion of Central European bows were topped with bone or horn and commonly replaced the quarrel groove of the western bow with a simple bolt rest at the very head of the stock. On plain bows this rest was carved from the stuff of the top of the stock, but on gentlemen's bows it was often dovetailed into the stock, and adjustable right-left. As on western bows, the roller nut release was usually of stag horn, but in western bows the nut ran free without any axle or pin (at most, a small one to prevent the nut's falling out) in its cylindrical socket. The central bow used a tight cord bridle through the center of the nut to keep it in place and to prevent it from oscillating or chattering in its slightly oversized cylindrical socket. Often the front and rear edges of the socket were reinforced with horn in both central and western bows.

Typical Western European Lock

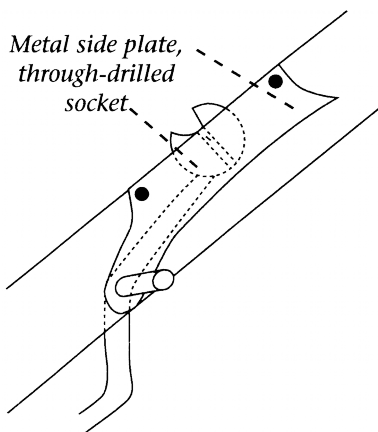

The metal side plate reinforces the gaffle cocking pin which also serves as a trigger pivot-point.

Fittings and Decoration

Western bows commonly had the nut socket drilled from one side, with iron lock-plates fitted on both sides, to reinforce the stock. These plates assumed a variety of functional or fanciful shapes.

Central European bows usually had their locks installed by insetting the parts in a rectangular mortise cut into the top of the stock. This method of construction leaves the sides intact, save a small hole for the cord fastening through the nut. This hole was often reinforced with an inlet triangle of bone or horn. Thus central bows often appear to have a side plate, though its function differs from the metal side plate on a western bow. Other pieces of horn or bone are often seen reinforcing the pivot-pin for the trigger, the hole for the bridle that holds in the prod, and the pins that support the cranequin. These reinforces range from functional diamonds or ovals through long fanciful flashes and squiggles running down the side of the stock. Nicer bows featured carving, in the form of geometrics, allegorical figures, or hunt scenes both in the horn and wood sections. Very expensive bows actually covered large sections or all of the stock with decoratively carved horn or bone. Generally you'll find less carving before the 16th century. The earlier bows mostly prefer geometrics and heraldic patterns. Middling 16th century seems to go for lots of figures and allegorical motifs, and by the 17th century, there's more floral and baroque decoration, and geometrics or biblical scenes. Please note this is a very

general observation and someone will prove me wrong tomorrow.

Triggers and Locks

The trigger systems of both western and central bows started out virtually the same, though the shapes of the triggers (tickler) differed in detail by the high middle ages. Western bows usually used an “S” curve trigger shape, whereas central bows favored “Z” shape with a sharp, reflex angle at the head of the trigger. The angle at which the trigger departs from the stock may vary by place and time as well. The late 15th century saw a new lock system for the better class of central bows. The two-axle lock seems to be limited to the latter half of the 15th century, but was followed in the 16th century by a multi-axle development of this lock (some have four or five axles). The complex and expensive multi-axle lock appears most commonly in central European bows, but can be found in some Flemish target bows as well.

Near the middle of the 16th century, the old roller nut lock in its various permutations was challenged by the central European clap-lock. This lock was well suited to medium weight bows used for hunting and target shooting. It was probably cheaper than the multi-axle lock and a bit quicker to set. On the heaviest bows, particularly in central Europe, the roller lock with several axles remained the favorite into the 18th century.

Spring Clips (Bolt-Clamp)

Most of my bows are fitted with a steel clip to hold the quarrel in place while shooting. In medieval bows, both western and central, these clips are rather uncommon. You'll find them, mostly made of steel or horn, more often on sporting bows. In some bows, the same effect was achieved by making the butt of the quarrel a jam fit between the lugs of the nut. This tight fit would require fairly consistent size in crossbow releases and quarrels, but very detailed guild regulations for crossbow and arrow makers may have achieved this. My limited observation of extant medieval bows suggests that five-sixteenths of an inch was a common width for the space between lugs. For lightweight quarrels used with very light modern bows, this jam-fit sometimes precipitates misfire problems.

I have never seen a brass clip on a bona fide medieval bow. I have seen triggers that were either brass, bronze, or gold plate over steel. I have seen at least one medieval bow with either a brass or bronze nut and some 18th century bows with brass nuts. In the early days I used a lot of brass and bronze for triggers, because it can be annealed in large lots in the ole' barbecue pit and then worked cold. Besides, people are a bit like magpies, we like shiny objects.

Nowadays, I use mild steel almost exclusively for triggers, stirrups, lockplates, etc. In practice, almost all medieval crossbows had iron or steel triggers. The spring clips, when present, were horn or steel. The nut was usually of stag horn, sometimes with substantial steel reinforcement. Steel nuts were fairly common for later bows. I have seen a photo of a wooden nut fitted in a medieval crossbow in a museum in Bern Switzerland. Unfortunately, the nut in question clearly did not fit the socket and would not have served any useful purpose.

Butt Shapes

Crossbow butts can vary by region as much as the rest of the stock. Most

western European butts were narrow and rectangular. Central European stocks usually have narrow, ovoid or rounded butts, though by the end of the 15th century, broadened cheek-pieces were beginning to appear on some bows. In such cases, the off-side of the butt appears quite normal, while the near side is widened and flattened, (sometimes hollowed) to form a cheek-rest. This gives the butt a rather triangular cross section, perhaps two inches on a side. In the early 16th century, crossbows (particularly German and Spanish pieces) began to feature an enlarged butt, usually with large cheek piece, much like the firearms of the day. By the mid 17th century we can find crossbows with enlarged butts and small triggers, with trigger guards, approaching what one might call a gun-shape, though the real musket (flask) butt that we know today dates from the early 18th century.

THE STOCKS

The stock patterns that I make are organized by my own method, based on their profiles. Early in my research I decided I had to have some regular method of referring to the various types. Now all my patterns have official designations, (as well as private “shop” names in some cases). In the following pages I will define and describe each pattern and give a brief sketch of the sources I used for that pattern. Some of these patterns, like German 15th and 16th century bows, are easy to document. Others, like Roman 5th century bows are based on the sketchiest of details.

New World Arbalest Patterns

Pattern #1: Straight, slightly tapered board. In the shop we sometimes call it “The stick” It is quite undistinguished. There are about a zillion medieval miniatures that depict crossbows like this. Some of those may reflect the artistic conventions of the time, but some show enough detail to suggest there really were bows that looked like tapered sticks. Some straight bows feature an enlarged head, much like the 4D Spanish bow, which you will encounter later. Certainly the 4D could as easily be categorized as 1B.

Pattern #1A: Derived from a carefully drawn 19th century set of drawings of an extant bow, showing several views and details of decoration. Egon Harmuth's *Die Armbrust*, (p. 112.) reproduces these drawings very nicely. The bow dates from the late 15th century, but such a pattern might well go back substantially further. This handsome central European bow looks like a no. 5 from most angles. I usually make them twenty-six to thirty inches long.

Pattern #2: Taken from miniatures from a 15th century edition of Froissart's *Chronicles*, as reproduced in several sources. It is shown as a large plain bow, spanned by a windlass, in a depiction of the battle of Crecy. In the shop, we call these “cricket bats.”

Pattern #2A: The Crecy number 2 bow is actually shown with the lock behind the enlarged front part of the stock. I think this is an artist's mistake, as there is no reason to put the lock in the weakest part of the stock, behind the reinforced section. I did build one like this, in black walnut with lots of brass trim. It looked impressive until you thought about it a minute, and then it just looked kinda dumb.

Pattern #2B: This stock was based on a Viollet le Duc illustration (19th century) from Payne Gallwey's *The Crossbow* (p. 80). I made one bow of this pattern. I thought it looked rather odd. The TV series “Covington Cross” used a similar bow, and it looked pretty good (not our work.)

2C. This stock is pretty well documented. There are numerous 15th and 16th century paintings that feature this bow, particularly Italian and Spanish. Of particular note is a St. Sebastian Martyrdom by Antonio Pollajuolo, dated 1475, with two 2C's and a Tintoretto of the capture of Constantinople by crusaders, with a large 2C spanned with a windlass. This bow is also similar to an illustration in the *Manessa Codex*, early 4th century, showing mounted German warriors on a cattle raid, though this may actually be pattern 4B. In the shop, these are “toosies.” I usually make them about twenty-eight to thirty inches length.

2E. Was taken from a museum catalog photograph of an English sporting bow dated about 1595. It is clearly designed to use the goatsfoot lever for spanning. The original appears to be fairly ornate, and looks rather Spanish in inspiration. It should

New World Arbalest Patterns

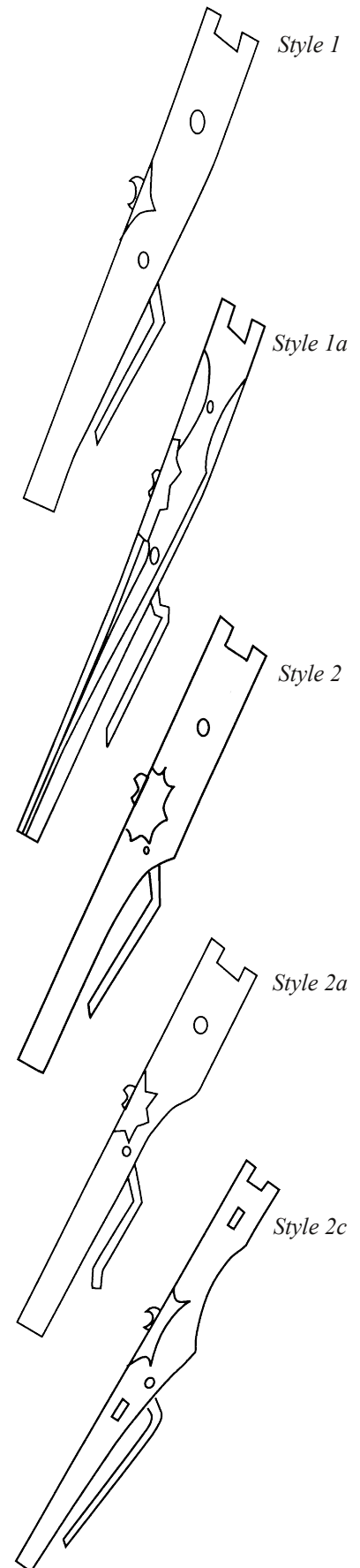

New World Arbalest Patterns

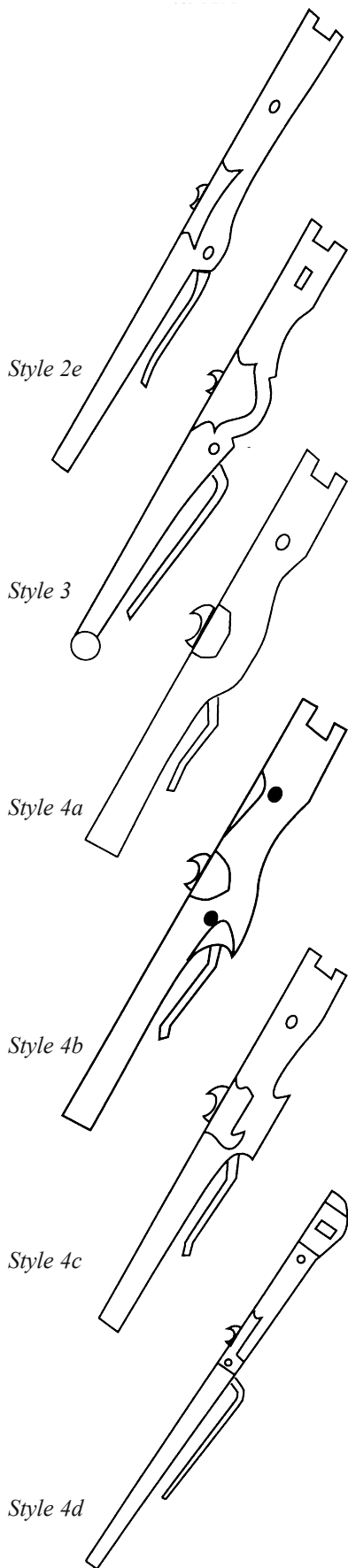

probably be about thirty to thirty-two inches long. We've made only a couple of these, though I like the look.

3. This stock is very popular with my customers. It has a nice medieval "feel." I am embarrassed to admit that I hijacked the pattern from a cheap Italian tourist-trap bow and have done a fair amount of modification to the pattern. It does resemble some of the extant large Italian siege bows, and I do not feel it does any violence to the medieval type, but it's a bit removed from good scholarship. I make these bows about thirty inches long. We call them "Italian ball butts."

4, 4E, and 4C. These stocks are versions of the common Flemish Arbalest that can at least be dated from the 15th century, in a constant state of evolution into the 20th century. The 4E in particular is based on an extant English bow, dated 1565, and patterns shown by Harmuth (p. 90) and Payne Gallwey (p. 92). Most of these bows fastened the prod with bow irons.

4C is a 17th century target bow based on the same type. (see Harmuth p. 90). These crossbow stocks were pretty big. Anywhere from thirty to thirty-six inches would be reasonable. In the shop they're "Flemings," but some old timers call them "Otisburgs."

4A and 4B are cavalry bows that bear some resemblance to the blocky no. 4. Both are related to the 14th century German bow from the Manessa Codex, mentioned under 2C. Cavalry bows are short; I make these twenty-five to thirty inches. I call 4B's "Burgundians" because I first encountered the pattern in a drawing of Burgundian horse bowmen from Funken and Funken's book. (see bibliography).

4D. For reasons too weird to explain, I list this bow as 4D instead of 1B. In the shop we refer to these delicate little Spanish bows as "padres." The small versions were light sporting or cavalry bows. Many of them saw use in the conquest of the New World, from 1492 on. They generally run from 28 to 32 inches in length. My pattern is taken from the remains of a bow found in a 1554 galleon wreck on Padre Island, in south Texas. The Albuquerque Museum (New Mexico) has a good example of the larger medium-weight military bow in the same style. It is perhaps thirty-four inches long. The big ones we call "Albuquerque," but "Als" would be easier.

The 5's: In many ways, stocks 1A, all the 5's 6's and 7's are part of a continuum of central European bows. When you've seen enough of them, they all blend together. So my numbers are just stops along the line. There are "5's" that have so little dimple in the bottom, they might as well be 1A's, and some bows I have in my photo collection may actually be 1A's that look like 5's, thanks to the camera angle. Many central European bows survive in various collections in Europe and the USA. The 16th and 17th sporting bows are the most common, but a number of 15th century bows survive, and there are even a few 14th century examples of 5's.

5. This stock is a round section "Germanic" bow of moderate length. Some are rather slender quarter bows, and some are heftier "half" bows. This pattern usually is tapered in width at the fore end, and some get cheekpieces. I make them twenty-eight to thirty-two inches long. Earlier 15th and 14th century 5's are usually rather long (three feet in length is not uncommon) and are relatively taller at the fore end and narrower at the lock than 16th century bows. The Hofburg, in Vienna has a large siege bow of this pattern (six feet long and wide?), and the Metropolitan Museum in New York has a long half-bow, perhaps thirty-six to forty inches of stock. Both of these bows are 15th century specimens.

5A is based on Payne Gallwey's illustration of a bow from the 'Armeria Real', in

Madrid (The Crossbow, p. 129). A 'slurbow' with a covered quarrel groove. I thought it looked sleek and pretty. I've done several of these bows. They're a bit rounder in cross section than most 5's, about twenty-seven to thirty inches, as they are probably sporting bows.

5B: This is a short, fat carbine of a bow. Some of the many extant examples are quite rounded, while others feature very flat surfaces and broad bevels that make them rather octagonal in cross section. These bows are mostly twenty-five to thirty inches in length, and are often highly decorated. The extant examples, and there are many, generally date from 16th and 17th centuries, but you see them as late as 18th century. Most were also provided with the complex multi-axle sporting lock. The common form of spanning machine was the cranequin. Excellent examples can be found in the Tower of London Hofburg in Vienna, Metropolitan Museum, and just about any other place fine weapons maybe seen. I once provided a model 5B to television's 'Buffy the Vampire Slayer.'

5F: It is taken directly from an article written entirely in Finnish, that has many illustrations of the process of replication of 15th and 16th century Finnish crossbows. These bows look a lot like a reputed 14th century Germanic crossbow preserved in Dresden. The Finnish article has clear drawings of several different Nordic bows, with useful metric scales alongside. All of the bows illustrated were about thirty-six inches long and very slender. I usually make them about 30 inches long. The originals used substantial amounts of moose horn in their construction. In the shop, they're "Finnbows."

5S: This stock has a profile like the central European 5' s, but it is quite flat sided, like most other western bows. Some are more elongated than I show them. Harmuth illustrates several pieces with this shape (p. 91), and Held's Arms and Armor Annual Vol. 1 (p. 34) has good pictures of a flat -sided 5, My pattern is taken from photos and drawings I made in the Hofburg in Vienna, which has three excellent examples of the 5S.

5U: was taken from a bow made for Ulrich V, Count of Wurttemberg, about 1460. This bow now resides in the Metropolitan Museum, New York. The pattern was originally sent by a friend, who copied it from the Baron de Cosson's 1892 article in the Journal of the Royal Antiquarian Society. The original is about twenty-eight inches long. In the shop, this one is "Ulrich." Lately it has become quite popular.

6 and 6B are based on very good illustrations of crossbows in Holbein the Elder's "Martyrdom of St. Sebastian," painted about 1500. Egon Harmuth's Die Armbrust shows a very similar bow on page two and there is an extant example in the Chicago Art Museum. This pattern has been one of my most popular for years. I make them twenty-seven to thirty-one inches long.

6C is my own spin on the type 6, with a few distinctive flourishes.

7 and 7A are in reality the same style. The originals are two bows, one a military bow in the Danish National Museum at Copenhagen, perhaps thirty-four inches long. The second is a twenty-nine inch sporting bow from the Tower of London. The Tower bow has a multi-axle sporting lock and probably dates from the early 16th century. The Danish bow is mid-to-late 15th century and has the old medieval single axle lock. I used to make no. 7 stocks bent in the tail, with a cheek piece, whereas 7A's were usually straight, sometimes without cheek-piece. Nowadays, I make most of them straight, though Holbein's "Martyrdom of St. Sebastian" has a number 7 that appears to be bent. This one is probably my favorite pattern. I have three of them! In the shop, they' re called "Tower bows" and

New World Arbalest Patterns

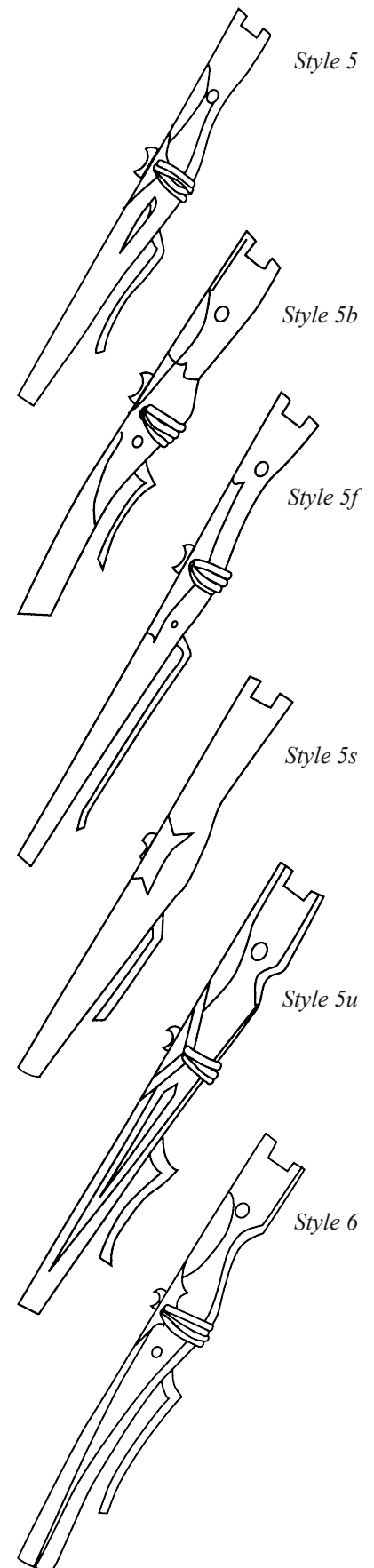

***New World Arbalest
Patterns***

Style 6c detail

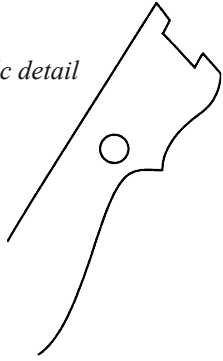

Style 7a

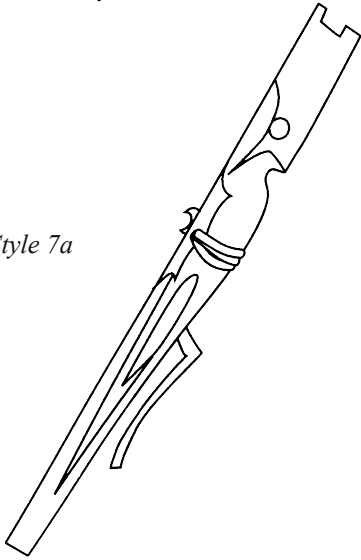

Style 8

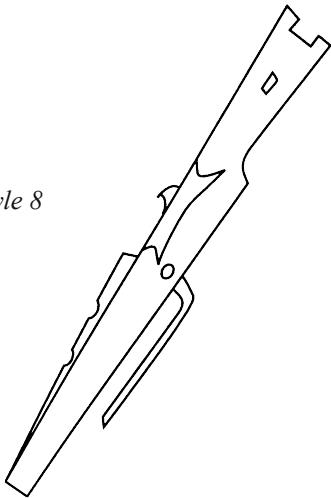

Style 9

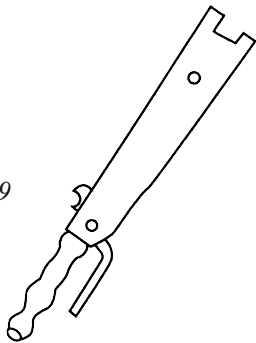

“Danish.”

8: An Italian 16th century sporting bow taken from Harmuth's *Die Armbrust* (p. 91). It's sort of funny looking, but rather dramatic. I like it. We call it the “lightning bolt.”

9: The Roman bow is based on two illustrations: A sporting bow that appears on a 4th century grave stone in France, and an engraving on Trajan's column of what is probably a robust military bow possibly with an enlargement of the fore end around the prod. It is short and strange looking, with its turned rear section, and properly done, should have no stirrup. (see Harmuth, pp. 20 - 21, and Held, *Arms and Armor Annual* vol. 1, pp. 56 - 65.)

GETTING WHAT YOU WANT (REPLICAS AND PARAPHRASES)

When people talk to me about purchasing a crossbow, the first order of business is to ascertain exactly what they want. (Which may differ from what they think they want.) Members of historical recreation groups usually want bows that would be appropriate for specific time periods and areas. That's usually not difficult to define, though I have encountered people who were determined to portray 16th century Flemings, but hated the 4E Flemish arbalest. As an alternative. I could recommend the light, slender 4D Spanish bow, the Maximilian 5S, or even German sporting bows as alternatives that would not be entirely out of place, thanks to trade, geographic proximity, or political alignments.

In a similar vein, I would expect 90 percent of the crossbowmen with Cortez in Mexico in 1521 to carry model 4D or 5S Spanish bows, but you might find a sprinkling of Italian, Flemish, or even short German horse bows. Generally, you're better off from a historical standpoint with the more common equipment.

Museums want formal display bows and demonstration bows for docents to handle. They need bows of correct appearance and proportions as close to the originals as possible. In most cases such customers are less interested in efficient operation than appearance, but I have yet to encounter a museum that simply didn't care if the replica worked. (I don't make inoperable replicas.) Due to the cost of materials and labor necessary to make rigidly correct display bows, few individuals are willing to invest the money necessary to make an exact copy of an extant period bow, or even a reasonably correct paraphrase of a period type of bow.

So what the heck is a paraphrase? I define reproduction work in three categories. First, there are copies: rigidly accurate representations of an extant bow or type of bow. Next, come paraphrases, which may differ in detail or decoration from the sample or samples, but are consistent with period practice and decoration for bows of the type. Third, and by far the most common, are the reproduction bows. These bows are correct as to type and general appearance and consistent in style and function. Numerous details may vary, and materials can be freely substituted for reasons of cost and convenience. The majority of bows I make fall into the reproduction category. These bows look right from three feet away, work right, and are reliable and safe for recreational shooting.

Generally use of these bows falls into three categories as well: Display, target shooting, and combat games. I hope any bow I make will meet an individual customer's needs for all these purposes, but it's difficult to have everything in one bow.

Combat bows are employed by armored or semi armored players wearing full head cover. They must be loaded and shot on the move, with great rapidity. Given the necessarily light weight draw of these bows, they are usually spanned while resting the butt against a hip. These elements dictate a horse bow (twenty-five to twenty-seven inch length) very handy and short enough to be held entirely in front of the face for sighting. Large infantry and siege bows are too difficult and slow to load and sight easily, given the full head cover.

In fact, Medieval warriors usually did not shoot from entirely closed helmets, and their bows were much too strong to pull against the hip. For game players, the requirements are a bit different, so the horse bows predominate for this use.

Persons using medieval-type crossbows for target shooting can comfortably use



*Type 1a central European, circa
1500*

the larger infantry-style bows, which most people find more comfortable and stable than the shorter horse bows. Though the evidence suggests medieval crossbowmen generally held their stocks from of the shoulder, many modern shooters, he long stocks can be rested against or atop the shoulder prefer to rest their butts shotgun-fashion. Target bows can be made for greater power than would be safe for combat games, but it is possible to ask for too much weight in a target bow. Most adult men find pulling crossbows in excess of 125-pounds fatiguing after a hundred or so shots.

Some 'medieval' crossbow competitions put a premium on a high rate of fire. In that case, very heavy bows may suffer disadvantages from slow loading that outweigh any advantage conferred by flatter trajectory.

Stronger bows also tend to be a bit heavier in the hand; Not usually a problem for target shooters, but strong bows must also be more carefully made, and require more expensive lock materials and prods. The lightweight inexpensive aluminum prods I use in recreational bows wear out faster than the stronger, but more expensive steel prods. The most serious target fanatics simply shoot too fast and often to make an aluminum prod practical. One of my friends spent several years firing in excess of 500 shots a week. Effectively he had to have a new prod every year. Fiberglass prods lasted more like two years. For him, the only viable option was a stout steel prod.

Most of my customers don't shoot 1000 shots a year. Their aluminum prods will never wear out. That is why I can offer a lifetime guarantee on aluminum prods, because most people will simply never shoot often enough, fast enough, to wear one out.

Decoration

Target bows often see a fair amount of wear, but do not receive the sort of abuse that a combat bow gets. Thus it might be reasonable to invest in more expensive decoration and performance options on a target bow. Display bows are the most expensive and demanding bows. Typically, medieval bows used very thick bowstrings and had relatively large fistmele and short draw. If we limit ourselves to thick bowstrings and short draws on light recreational bows, we will have to accept lower performance than we would get from the same prod with a longer draw and a thinner string. The only really affordable prod we can get that closely matches the material and style of medieval bows is the steel prod. Though steel prods are very reliable, they suffer a substantial penalty in weight and increased recoil. The aluminum prods make quieter, more efficient crossbows that are easier and more fun to shoot, but they won't last nearly so long.

So display bows that are optimized for appearance tend to be bows that require heavy, expensive prods, horn releases, all steel triggers and tackle, fancy inlays or overlays and other expensive decoration. These bows will shoot effectively, but they will be more expensive and will probably have lesser performance than bows optimized for target shooting.

Making up your Mind

It is not uncommon for a customer to have only a vague idea why they want a medieval crossbow, except for its being "neat." That's plenty of reason to start with but, it does help to have some idea what the intended use is.

There is no way I can entirely know the real needs of my customers, but I do make an effort. For starters: I recommend that combat bows be kept very plain, as

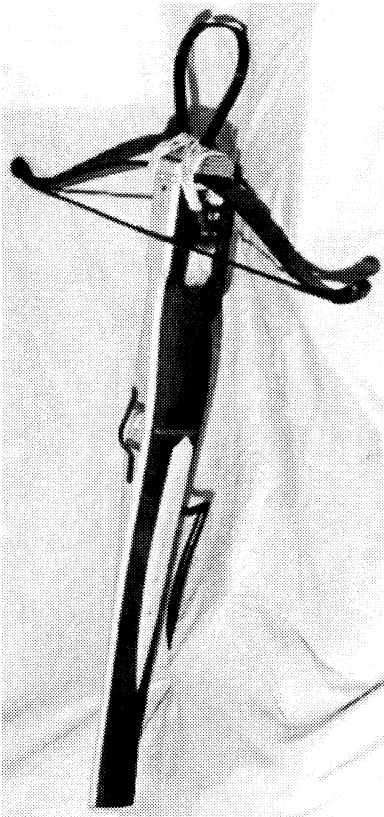

*Type 5u central European,
circa 1460*

fancy decoration will probably be spoiled the first time the bow goes on the field. Target and display bows are a different matter. Prettier bows get more positive feedback from your friends, and usually engender more satisfaction in ownership. For instance, a horn nut really is better and a brass nut lesser in most respects. I tell my customers to buy horn, if they can afford it, because its what they really used 500 years ago, and it works better. Otherwise, a cheap-o Delrin nut looks much the same from 5 feet and works great. Horn or Micarta tops really do reduce friction, for a faster cast, but a maple top on is nearly as pretty for less cost. I only recommend a horn or Micarta top if you' re really picky about appearance and want the highest available performance.

At the end, every potential crossbow customer has the same decision to make as his 15th century forebears. Fish or cut bait? Sports bow or war weapon? Maximum efficiency or prettiest finish? Sometimes throwing extra money at the problem will solve some of the dilemmas, but nobody gets everything all the time. Sometimes there are no clearly defined best choices. Then you have to fall back on aesthetics and the size of your pocketbook.

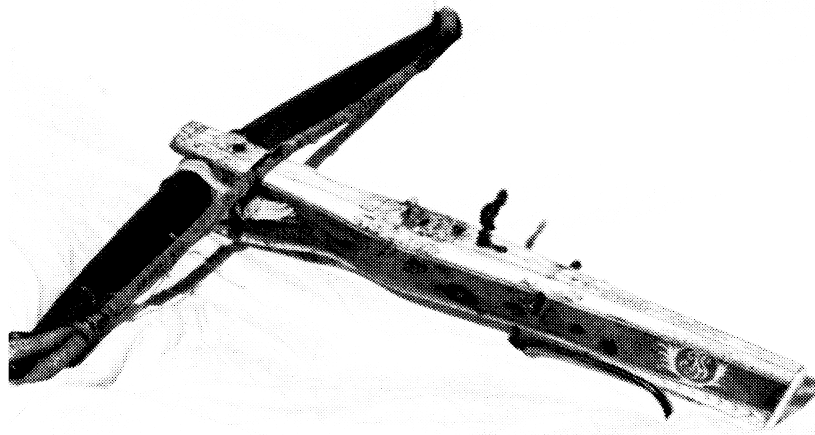

Central European 1586 (type 5b) in a private collection.

GETTING THE MOST OUT OF A MEDIEVAL CROSSBOW

To get the best performance from your medieval crossbow, you need to do three things: First, get your bow in top shape, Second your projectiles must be as close to perfect as possible, and Third, you must have consistent shooting technique. Note I didn't say perfect, just consistent.

The Crossbow

First we will consider your bow. We will go front to back. The bow stave (prod) must be well secured in the stock. This means the bindings must be brick hard and the bow immovable in its socket.

The prod should be completely square and centered in its socket and it should not be bent, chipped, scratched, or split. The string should not be frayed or worn, all serving should be intact, and the string should have no broken strands. Strings with broken strands will cause erratic shooting and misfires. Ditto for loose prods, which also contribute to excessive recoil, jolting, and noise. The best shooting bows will have very little string drag on the top of the stock, as drag wears the serving and eats power. String drag does produce a quieter bow. Lubricating the top of your stock will reduce the deleterious effects of string drag, as well as increasing power, accuracy, and string life. I prefer modern spray silicone for this. Graphite makes a mess. Tallow or bees wax works pretty well, once its worked in, and that's probably what was used in period. Excessively thick or thin bowstrings may have misfire problems. The string should not be less than about 50 percent the thickness of the quarrel, or noticeably thicker than the quarrel. Some serious target shooters make their crossbow strings from hard, strong modern fibers, like Kevlar (or Fast Flite). These fibers will give a noticeable improvement in speed of cast, but may also cause aluminum or fiberglass prods to fatigue faster than they would with softer, stretchier strings. Very narrow modern strings may encounter misfire problems as well. Such problems may sometimes be solved by double-serving the center of the string.

The quarrel groove or rest should be well centered in the top of the stock, slick, straight, and not too deep or wide. Some medieval and Renaissance sporting bows had movable quarrel rests. Moveable rests made it possible to do fine adjustments for windage or minor flaws in the geometry of the stock. On the other hand, bows with moveable rests may show erratic behavior if the rest is too tall (quarrel will porpoise) or if the rest is off center (quarrel will fishtail or whirligig). Fishtailing can also be caused by the pulling the string off center when you span your bow. To avoid this problem, mark the center of the string and be certain to pull the string evenly and simultaneously from both sides of the stock when spanning.

The advantages of the bolt rest are that it can be moved, will increase point-blank range a bit, and can be made of a low-friction material quite easily. Advantages of the groove are that the quarrel is more securely held in place, and these bows have less minor teething problems, such as misfire, porpoising, and fishtailing.

The Lock

Your lock should be free-running, without excessive slack or wobble in its

String Pressure

Optimal — very little pressure

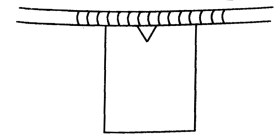

Too much pressure wastes power

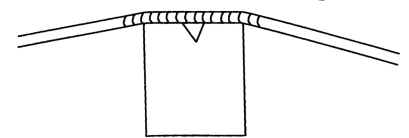

Flies (no down pressure) — may misfire

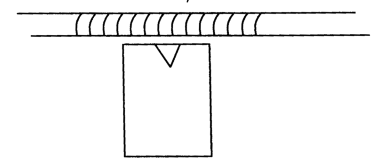

How string pressure on the top of the stock affects performance.

socket. A lock that's a bit too tight is not unsafe, though a really tight one may occasionally misfire. Very high humidity will sometimes make a lock rather tight. Occasionally a loose lock may jam in the top of its socket. This jamming can be temporarily set right by the simple expedient of smacking it on top with the heel of the hand. It may be necessary to replace the edges of the socket, or replace the nut on a bow that jams a lot. (This is not a big job.) The sear pin in the nut (where the trigger fits into the bottom of the nut) should not be excessively worn, but even a worn sear should be safe to shoot, so long as the trigger engages fairly deeply. It is normal (though not desirable) for the nut to develop a trigger-wear groove around its middle. The wear can be reduced by pulling the trigger fairly quickly, and pulling it well clear of the release point.

Commercial arrow points

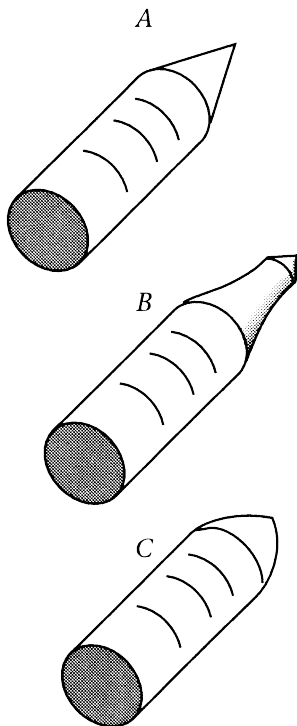

*A is a target point.
B is a field point.
C is a bullet point.*

Period crossbows have several different forms. Long stocks can be conveniently shot from atop the shoulder. Long, bent stocks can be placed in the hollow of the shoulder like a shotgun. Very short stocks are shot from beside the cheek, or held free of the body, before the face. These last, very short bows would include Chinese pistol bows and short European cavalry and sporting bows. I suspect short European crossbows were held clear of the body so that the butt of the bow could be lowered to increase elevation. This allows the shooter to keep his quarrel point on target regardless of the range, whereas elevating the head of the crossbow quickly causes the fore end of the weapon to obscure the target as the range increases.

Quarrels

A noted modern archer has been quoted as saying to shoot well, buy the best arrows you can possibly afford, and with any money left over, buy some kind of a bow. There's truth there. You cannot shoot well without good, consistent projectiles. So what makes a good projectile? Your quarrels should be all of the same weight, length, thickness, spine, etc. The fletching should be perfectly placed and of the same size. The sticks should be very straight, not warped, bent, or split. They should be effectively identical. Now as to the particulars.

Length

Longer quarrels are more stable than shorter ones, but have more surface drag. They require a higher apparent aiming point, and when shot into a target, they will stick further out one side or the other. They will be easier to recover and less likely to damage fletching. They are, of course, heavier, and will fly a little slower. Over about fifteen and three-quarter inches in length, they will be a bit more costly, as arrow shaft comes in thirty-one-and-one-half-inch lengths. Hence a seventeen-inch quarrel requires an entire stick, whereas a fifteen-inch quarrel requires only a half stick. Short quarrels are lighter, faster, less stable, have less surface drag, and require a lower aiming point. They go relatively deeper into a target and are more difficult to remove. I used to make all my quarrels ten inches long, so I could get three per arrow stick. I eventually decided short quarrels were not a good value, due to lesser stability and their tendency to bury themselves in a target and strip off their feathers. Note: If the quarrels that flew just fine on the rainy archery range yesterday don't fly well today, look at your feathers. If they are all mashed and flattened, steam them out nicely over a kettle. Commercially available target heads range from about 70 to 150 grains in weight. The most common points are 110 and 125 grain field points. Heavier heads are more stable, but very light crossbows of 300 to 600 inch/ pounds will perform better with a long shaft (@fifteen inches) and a 70 grain head. 1000 or more inch/pound bows will do better with 125 or 150 grain heads.

Heads must be put on squarely. You can tell if they're straight by sighting down the shaft from the rear and rotating the shaft or by putting the point on a hard surface and spinning the quarrel like a very tall top. Straight quarrels with straight heads will not wobble.

Shafts

Cedar arrow shafts are very strong, resilient, and light. They are available from 5/16 to 23/64 inch diameter. If you shoot a very narrow shaft, you will do better with a narrow string. Spine weight (stiffness) does not matter with crossbows as much as it does with hand bows, but it is possible to use a shaft that is simply too flimsy for a strong bow.

Birch and ash make good quarrels, but they are heavier and stiffer than cedar. Ash was considered the best wood for war quarrels in the Middle Ages, because of its weight and resilience. For shooting in lightweight crossbows, they will prove very strong and resistant to breaking, but they're gonna be heavy and slow, hence a bit less accurate at longer ranges. Some fletchers use poplar for shafts. It is lightweight, but often needs straightening in the fletching process.

Fletching

The fletching of your quarrels is very critical. Feathers may be purchased as right or left wing. It is less important whether you buy right or left wing feathers, than it is that you use all of one type on the same set of quarrels. The feathers may be put on the shaft in any of number of ways. Most, but not all medieval quarrels used two vanes 180 degrees apart. Some medieval quarrels may have used three feathers at 90-degree intervals. Some quarrels had their feathers put on the shaft at a slight angle to induce spin. These quarrels were called "viretons." A little spin will usually make your quarrels more accurate, but excessive spin will reduce range, and may cause a marginally stable quarrel to be even more unstable. Whether you spin your quarrels or not, you should endeavor to place the side feathers at right angles to the grain, and make sure they are precisely opposite each other. Theoretically two feathers with moderate spin should give you the best accuracy and performance. Adding a third or fourth feather increases the probability of getting one a bit crooked and increases drag. If you have two feathers and one is crooked, the quarrel will fly badly. If you have 3 feathers and one is crooked, the quarrel will fly with reduced accuracy, but probably not abysmally. A third feather, on top of the quarrel may interfere with target visibility at close range and may slightly unbalance the quarrel. Some people build their quarrels to spin clockwise, some counterclockwise. Some use helical feathers, and some flat. I think these details are less important than consistent placement of heads, feathers, etc. Good shooters will carefully weigh their quarrels on a sensitive scale. Bolts can be made lighter by carefully drilling a bit of wood out of the center of the butt and heavier by dropping very small shotgun shot into the head before gluing on. Quarrels that are consistent in weight within plus or minus five grains are generally considered matched for weight.

Feathers that become matted or warped can be steamed over a kettle for a few seconds and stroked back to shape. Bolts that become split can be glued back together, generally at the cost of a slight increase in weight. Badly split bolts should have their heads and feathers salvaged. The old wood can be cooked out of the head, and recycled feathers can be used on loaner quarrels, if not on target quarrels.

You should never loan your best target quarrels to anybody, not even your

Correct and Incorrect Fletchings

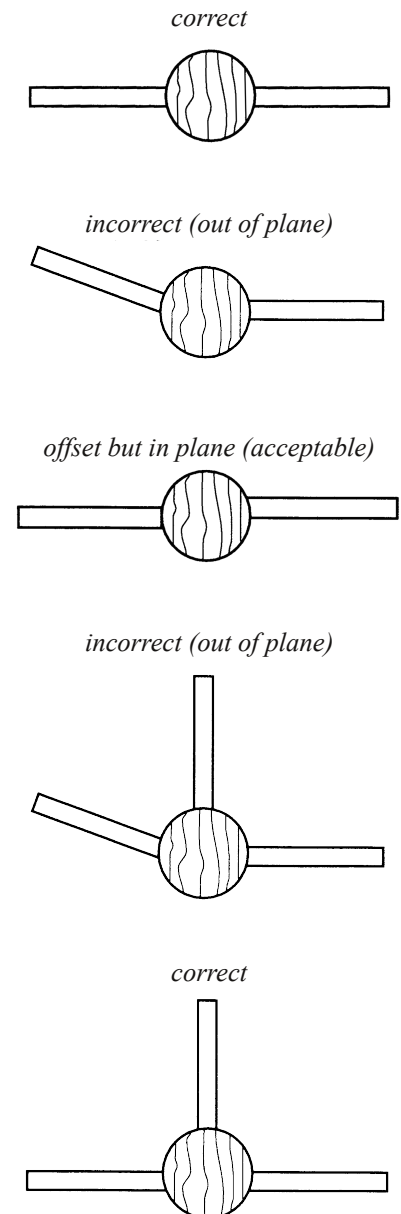

Precise fletching is the key to good quarrels. Vanes should be in plane with each other. Side vanes should be run perpendicular to the grain of the shaft.

Quarrel Maintenance

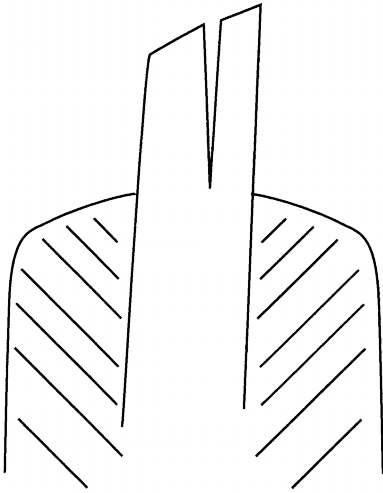

Damage like this can be repaired by gluing and clamping the split, then squaring up the butt once the glue has dried.

A Period Butt

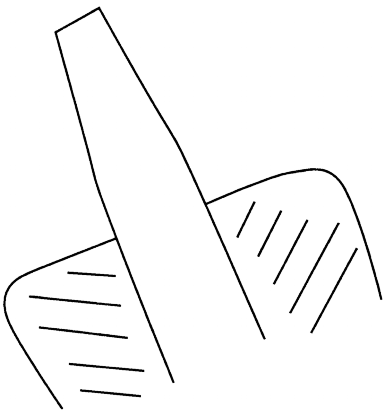

Period butts had no nocks and were often tapered for a jam-fit into the lugs of the nut.

sweetie. You need a second best set for friends and general practice and a loaner set of throwaways for anybody else who wants to try your bow. Butt ends of period bolts are usually just nice and square. They have no nocks or caps and usually no reinforcement of any kind. If they are cut crooked, they will not fly accurately. Some period bolts were shaved and tapered at the rear, for a jam-fit between the lugs of the nut. The jam fit pretty well obviates any need for a spring clip to hold the bolt in place, but very light modern bolts will sometimes get knocked askew by the motion of the nut.

As long as your bolts are unsplit, and lodged firmly against the string before shooting, they should not split or break on release, particularly if the grain of the quarrel is perpendicular to the lie of the string.

One last thing about your bolts. If you go to a first class fletcher who understands crossbow bolts, you can get some very good projectiles. Eventually you will want to make your own bolts at least part of the time. If you make your own bolts, you can cut the price to half. Fletching equipment is not expensive, and the basic skills are not hard to master. It is more fun shooting if you make your own quarrels, and if you decide to buy a first class set of quarrels, you will be able to recognize good work when you see it. There are plenty of people who will sell you bolts that won't fly straight.

Shooting Technique

Shooting technique is like many other subjects. Everyone has an opinion. It seems safe to say that what you do is probably less important than the necessity of always doing the same thing. Before we go to what you should be doing, lets make a quick review of what you should be avoiding, to prevent injury to yourself and others.

Remember, when loading your bow, do not put a quarrel in the spanned bow until it is POINTED DOWN RANGE. Remember that long medieval triggers are easy to set off accidentally. Don't put your fingers up in the way of the bowstring when shooting. Don't put the bow down loaded, or brace it against a table when loaded, etc. It will probably go off and shoot you or a friend. Do not point a loaded bow at any thing you do not intend to shoot. If you do so, somebody is likely to take your bow away and stuff it up your nose. Note that medieval crossbows are large and will not fit comfortably into your nose or any other bodily orifice. So don't be stupid, okay ? Now that we've told you that crossbows are subject to all known laws of physics Do Not Eat. This bow may fall from window if not properly supported in the installation process. May contain one or more harmful substances. If injected into your body, do not induce vomiting. Don't poke your brother in the eye with the ends of the prod or trigger. Use of your bow will cause an increase of entropy in the universe ---- Got it? Good, now we can talk about shooting.

To shoot well, you need to find a steady shooting position. I shoot sitting, with elbows on knees. You should always adopt the same position, and it helps if that is a comfortable one. When you shoot, be aware that release is not instantaneous. Hold still a couple of heartbeats before dropping the bow to see where your bolt is going.

If you tilt the bow right or left, the quarrels will tend to go in the direction you are tilting. Similarly if you are shooting in a crosswind, banking your bow into the wind just a few degrees will allow you to correct the wind drift and to keep the same sight picture you usually use. Many people who complain that their bows shoot consistently left or right are actually banking their bows in that direction, often in an attempt to get the eye more completely centered over the stock.

Particularly if you are shooting without sights, you should always hold the bow and release the trigger in the same way. Muscular control is very important. If you can't hold the bow really still when shooting, try drifting your bow on target from one side or the other, or from below, and release at a predetermined point in your swing. Be sure that you sight with your right eye if you shoot from the right shoulder and your left eye if you shoot from the left. Cross dominant shooting, shooting with your left eye from your right shoulder, doesn't work at all well. Control your breathing—take a big breath, let it out, take another breath, let out half... then squeeze the trigger. Try to be as peaceful as possible on the range. Don't allow yourself to become angry or distracted, and be careful not to disturb others when shooting in a group.

Grouping your quarrels is an important prerequisite to good shooting. If your quarrels are all over the target, it's hard to determine what is wrong, but if they're all low and right, all you need to do is move the group to the center. Many people allow the bow to jump, say low and right on release. Part of the muscular control trick is to release the trigger while keeping the rest of the crossbow completely still until the quarrel is well down range.

Another common flaw is pulling the bow off square when spanning. Many good shooters stitch a bit of colored thread around the very center of the string, for a visual check to see that the string is really centered in the lock. Others use two threads for opposite sides of the nut. This is helpful if you're shooting with the spring clip in place. You won't have to move it to see if your string is centered.

If there is any play between the quarrel and the lugs of your nut, it matters if you center the quarrel or put it against the right or left lug. There will be an optimal position for the quarrel, but unless there's a lot of play, you can usually settle for whatever position you like, so long as you always use the same one.

When shooting on a range with Others

Make sure everybody stops shooting before anybody goes down range. Make sure your range is safe, don't use the local day-care center as a backstop. It's a good idea to establish who is in charge at a range, and that person will announce aloud when people may commence shooting and when bows must be unloaded and people may go down range. I have no interest in establishing specific range safety rules for you, but if you shoot in inhabited areas, or with others, you **MUST** establish some basic rules to ensure that nobody gets shot. Do this **BEFORE** you have an accident.

Medieval bows, like much of premodern technology, have only one safety feature, **YOUR BRAIN**. You must train yourself to follow safe procedures. No safety, warranty, or insurance scheme works as well as a little presence of mind. As to best shooting techniques beyond the few principles I've laid down here, everybody's built differently and has a little different psychological makeup. I learned to shoot effectively thirty years ago in a small-bore rifle club. I learned a lot, and also learned I do not have the psychological set or the body to make a really good shooter. Remember, the first rule is to practice. Even practicing everything wrong will eventually get you somewhere, and the best shooters find a sort of Zen place within themselves that lets them focus everything on one goal. Now go shoot a bunch!

Shooting Flaws

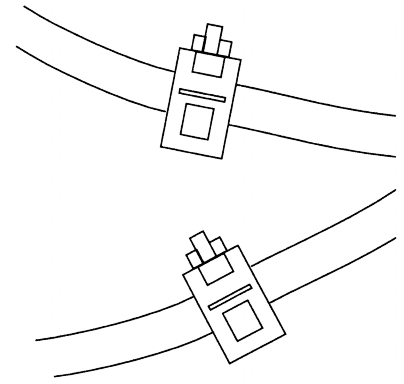

Rolling the bow left or right will cause it to cast the quarrels in the direction the bow is rolled. In other words, if you are getting tight groups, but they are right or left of center consistently, you are most likely rolling the bow.

Quarrel Grouping

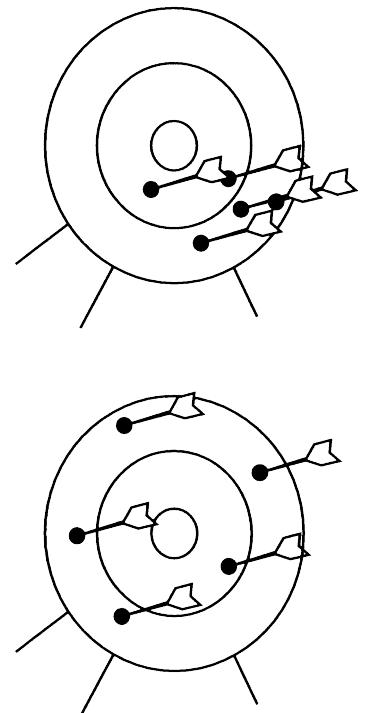

The top target has a group the is low and to the right. The bottom target has a scatter pattern.

WHEN THINGS GO WRONG

Simple medieval crossbows have few moving parts and are usually very reliable if made correctly in the first place; however, any machine will occasionally malfunction or inevitably wear, and things will go wrong. We will take the crossbow front to back, and look at each part in turn to discover what can go wrong and how the problems can be fixed.

Remember when troubleshooting that the most common failure is in the shooter, rather than the machine. I find that 90 percent of the complaints of misfire and erratic flight can be attributed to the shooters either pulling the bow off square on loading or not planting the butt of the quarrel squarely against the string. After that, I look at the quarrels, bowstring, and bow binding. If those look okay, I look at the lock. Just as with an auto, in which you check spark plugs before you tear out the valves, you want to examine the simple possibilities first.

The Stirrup

The stirrup at the head of the stock will be bolted on, bound on, or clamped in place with bow irons. Stirrups usually are not subject to many problems that will effect performance. Bolted-on stirrups aren't very medieval but they are usually trouble free, short of the bolts getting loose (tighten them). Many of my older bows used a bolted-on stirrup. If you put the crossbow down on the ground and step on it, the stirrup and mounting bolts can split the lower jaw off the fore stock. This damage can usually be remedied by simply gluing and pegging the fractured section back on. Bolted-on stirrups can usually be replaced with bound-on ones and the holes pegged and disguised if you want your bow to look a bit more medieval.

Bound on stirrups can occasionally work loose in their bindings, but they can be tightened up to a point. Sometimes a loose bound-on stirrup may have to be rebound, possibly in association with the prod, as the stirrup binding is usually combined with the prod-tightening process, even though their cords are separate. Many period bows did not share the prod binding or tightening in any way, but binding and tightening the stirrup entirely separately is a more difficult and time consuming proposition, and I usually double up the job. If a stirrup is loose and the prod is tight, there's little point in tightening just the stirrup, but if you must do something, just drive a couple of small hardwood wedges beneath the stirrup-from both directions of course. That oughta' do it.

Bow-iron clamped stirrups share any problems directly with the prod-clamping duty, if they stirrup is loose, the prod will be, too. We'll talk about keeping in prods down the way.

Prod Mountings

The most common mounting for medieval crossbows is bound in. The next most common is probably bow irons. There are a few other mounting systems, but I have had little experience with them and will not presume to comment on them. Prods that are improperly mounted or loose may cause your bow to shoot noisily, have increased recoil, or misfire - either causing bolts to hop into the air, to flump off on to the ground or to flying a fishtailing or whirligig pattern. When the bow maker mounts a prod, he will endeavor to place the prod precisely square in its socket in the fore end of the stock. "Precisely" means with the center of the prod at the center of

String Position

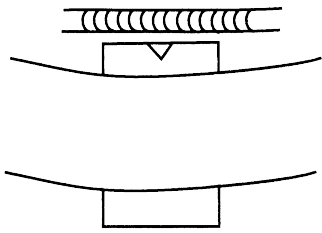

The string should kiss the top of the stock, not visibly fly above it as illustrated in this example

Pitch of the Stock and Prod

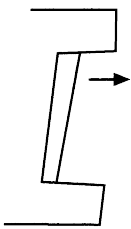

A straight prod will have to be pitched forward more than an asymmetric one in order for the string to glide over the top properly.

Prod Bindings

Not noticeably compressible

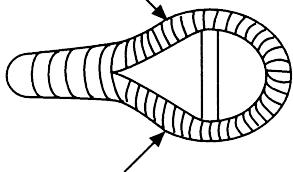

Not noticeably compressible

The bindings must be very tight and hard to keep the prod from shifting in its mountings.

the socket, right-left and with neither end of the prod forward of or above the other. Within certain constraints, it helps to have the top of the prod fairly near the top of the stock, so long as there's enough wood in the top of the socket to resist breaking it out. The prod should also fit as tightly as possible in the socket, top to bottom. Most of my prods are mounted with a very slight forward pitch, to reduce downward pressure of the string along the top of the stock. This downward pressure will decrease string life and waste energy through friction. Asymmetric prods, those whose ends curve upward, will use less forward pitch than symmetric ones. The trick is to adjust the prod so that the string glides over the top of the stock with just a few ounces of downward pressure. If the prod is so placed that the string flies clear of the top of the stock, it may show a tendency to hop out of the lock on release, missing the butt of the quarrel. We'll get further into misfire problems when we get to the lock.

Suffice it to say that the prod must be very square and tight in its mountings. Bows that are not square and tight will misfire or shoot their bolts with a fish tailing motion (yaw) in the first few yards of flight. Severely loose or crooked prods may cause extremely erratic behavior in bolts. Loose prods will be noisy and have an unusual amount of recoil. You should not be able to shift a tight prod in its mountings, and bound-in prods should have bindings so hard and tight as to be effectively unyielding to compression of the skein. When you mash the skein with your fingers, it won't move at all. It should feel hard as a brick. Sometimes metal prods will wear the binding cords and eventually cut them where the binding crosses the edge of the belly(rear edge) of the prod. This cutting action can be avoided by using a very wide binding (bridle block) or by padding the edges of the prod with a bit of leather.

Prods mounted with bow irons are easy to disassemble and reassemble, but you have to be very careful to mount them squarely every time. When the wedges are driven in to lock the bow irons in place, they must be driven very tightly, and they usually have to be tightened after the first twenty or so shots. Some bow irons work loose readily. This problem can sometimes be remedied by placing a thin piece of leather between the wedges to prevent their slipping. Wedges that don't respond to this treatment should be replaced with flatter wedges, as those that are too steep will not hold well. Bow iron mountings are a little noisier than bound bows and are also heavier. That's more weight to carry, but also more weight to dampen recoil as well. They are rather handsome to look upon. Historically they appeared more commonly on western European bows than central ones, but there are extant examples of both types.

Prod Failures

Occasionally a crossbow prod will fail. These instances fall in to two categories: bending and breaking. Bent bows are sometimes a bit difficult to detect. If a bow begins to shoot erratically where it has been reliable before, particularly after a new string is put on the prod, or after a violent meeting with the ground or other solid object, you should look carefully to see if the prod appears to be overly bent on one limb. A broken prod will usually be obvious to everyone.

Some medieval bows have wooden prods. Like wooden hand bows, these must be maintained carefully. Wooden prods should have their strings removed when they're not in use. They should never be stored with weight on one or both ends of the prod. Wooden prods should be inspected occasionally for cracks or delamination (splitting longitudinally through the prod, usually top to bottom). Like all springs,

wooden prods have a limited working life. Most wooden prods will announce their impending breakage by ominous creaking sounds. If you fear breaking of any bow, either quit using it or arrange a cover or safety-strap along the back of some resilient, springy material like sinew or rawhide. When changing the string on a wooden prod, you should always use a bastard string.

Most modern made reproduction medieval crossbows will have aluminum, fiberglass, or steel prods. Steel prods are close to permanent. They require very extensive shooting to wear out. If over strained, they may bend or break. With light bows of under 100 to 150 pounds, the prospects of breaking a metal or fiberglass crossbow prod need not be too daunting. If they break, they generally do so as you are placing the string in the lock. Your hands and torso are more at risk than any other part of your body, and with a light bow, you're more likely to be cut or bruised a bit than badly injured. Stories of prods that fail catastrophically, throwing numerous pieces about, may be regarded as probably spurious. After hundreds of crossbows over many years, I've never seen a metal bow fragment. Wooden prods can indeed break to little pieces.

Fiberglass prods are much more efficient than steel ones. (What isn't?) They last about twice as long as aluminum alloy prods. Usually fiberglass prods will show some signs of delamination along the top or bottom before failing. They are easily damaged by chipping or scratching. Fairly minor surface flaws can grow into delamination, though this is usually visible before failure occurs. Fiberglass prods should be carefully handled to avoid damage or should be covered with a thin leather or even, as in some Barnett prods, a thin plastic coating to prevent damage to their surfaces.

Aluminum alloy prods are about as fast and efficient as fiberglass ones, but they last about half as long. I estimate the life expectancy for my aluminum alloy prods to be about 10,000 shots, depending on how hard the prod is being stressed. Pulling the to a longer draw from a larger fistmele wears it faster, as will very fast shooting and hot weather. Aluminum alloy prods are very inexpensive to make and are very efficient, so they are very popular for lightweight recreational crossbows.

Metal prods usually break without any noticeable warning. Visual examination will give you no clues, and you'll hear no ominous sounds. In some cases, the bow might suffer a sudden diminution of power, but you probably won't notice that before the prod fails. A light aluminum prod will fail suddenly, and you might get a slap on the hand. This breakage will be scary, but not very dangerous. Most of my aluminum and fiberglass crossbow prods are made with a thin rawhide covering that simultaneously hides the non-period appearance of the modern material, and ensures that should the prod fail, no one will be injured.

Aluminum prods sometimes take a permanent bend if struck very hard on one end, and sometimes bend through disproportionate strain to one limb in mounting a new string. It is often possible to bend the prod back out to its original shape for further effective service, but given the low cost of such prods, I usually just replace bent prods with new ones.

Bowstrings

The condition of the crossbow string is as important to good shooting as consistent quarrels or a smooth-running lock. Ragged bowstrings, or strings with broken strands can cause problems from diminished accuracy to misfire. Every crossbow has an optimum brace height or "fistmele." This height is the recommended distance from the belly (inside surface, nearest the shooter) of the

Brace Height and Draw Length

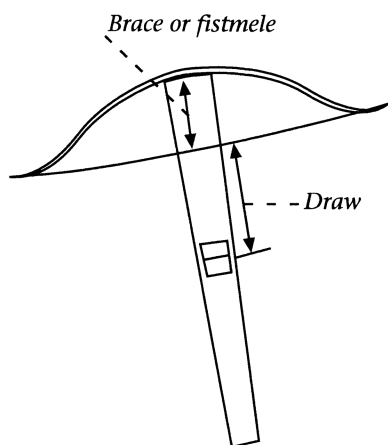

New World Arbalest bows usually have a fistmele of three to three and a half inches. Their usual draw length seven and a half inches. Period bow fistmele heights range from three to five inches, and the draw lengths from four to nine inches.

String Servings

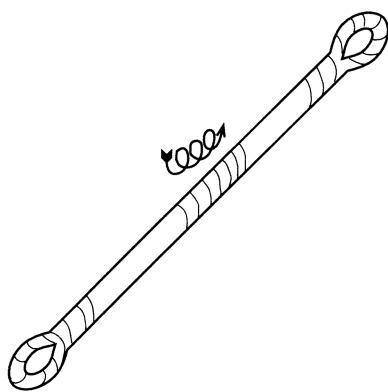

*To adjust for optimal fistmele, the string can be twisted and thus shortened it. **There is a caution:** The servings, both the ends and the center, must be wrapped in the same direction or the servings will come undone.*

prod to the position of the string at rest. If the fistmele is too large, the prod may be overly strained when the string is drawn to the lock. If the fistmele is too small, the string may throw itself off of the ends of the prod on release, as will sometimes happen with a misfire, even if the brace is correct. On medieval bows, the fistmele appears to have ranged from @ three to six inches, and on most extant bows, its around four to five inches. My bows usually use three and a half inches, but they also draw about an inch over common medieval practice, so the proportions of the bow are about the same. Fistmele can be adjusted by the simple expedient of removing one end of the string from the prod, twisting it a few turns and placing it back on the prod. Properly made strings will have all of the serving on the string wound in the same direction. When a string is twisted to shorten it, it should be twisted in the direction the serving goes to avoid loosening the serving. Shortening the string will increase the measured draw weight of a prod, but it will reduce the length of draw a corresponding amount, so there will be no real increase of power. I used to make most of my strings of Tandy's "artificial sinew" a nylon blend fiber that is heavily waxed and has the look and feel of a period sinew string. These strings are strong and long lasting, and they have a bit of flex that saves the prod some fatigue stress when stopped by the string in shooting. These days I use Dacron B-50 which is less stretchy and a bit stronger. This makes a narrower, faster string that will get a bit more cast from the prod, at the cost of a harder stop, and consequently slightly greater fatigue and wear on the prod. The old art-sinew string looked a bit better, but the Dacron has the advantage in performance.

Strings that have worn, loose, or lumpy center servings may shoot erratically or inaccurately. Bad servings or a broken strand in the string may also contribute to misfire problems. You can usually tell if a string has a broken strand by a small groove running the length of the string. Broken or loose serving at the ends of a string will allow the underlying fibers of the string to be cut by the prod. Experienced shooters always carry an extra string with them when they go to shoot. If you repair your string at the first sign of excessive wear, it should last for several years. Some modern manufacturers proudly proclaim that their strings are good for hundreds of shots. Any well-made string that is properly fitted to a well made and designed bow should last many thousands of shots.

Strings that are too thick or too thin may also cause problems. Generally, thinner strings are faster, but not as strong, as thicker ones. As a rule of thumb, strings should not be much smaller than half the thickness of the quarrels or thicker than the quarrels. Thick strings will sometimes run right over a quarrel, and thin ones can get under. Occasionally switching to a thicker or thinner string will mysteriously cure a misfire problem. Generally this means the size of the string may have contributed to the problem, but may not constitute all of the problem. So changing a string may not effect a complete fix.

There are several methods for mounting and dismounting a string, and all of them run some risk of permanently bending a metal prod, or cracking or breaking a fiberglass or wood prod. The simplest way to put on a string is to get a friend to help you. One person stands the bow on its butt and then depresses the ends of the prod (hands as far out toward the ends as possible), as evenly as possible, until the other person can remove one end of the string from the prod. Depressing the ends sufficiently to remove both ends simultaneously may bend the prod too far for safety and is a lot more difficult. This system will usually suffice for light weight bows.

Stronger bows, about 150 pounds or more, will require a bastard string. This device is clamped to both ends of the prod. A stout cord is then attached to the clamps. The cord is then pulled to the lock, which should bend the prod sufficiently

to put the bowstring on the ends of the prod. If more bend is necessary, pull the cord a bit behind the lock until sufficient bend is attained to have a friend slip the string on the prod. Note that if the cord of the bastard string is not sufficiently strong, it may break suddenly while you're putting the string on. You could be injured, so try to keep your hands clear of the probable path of the ends of the prod.

Once you have the string on the prod, gently let the bastard string down to rest, and pull the bowstring back to the lock. This action will let you take the bastard string off easily. Now let the bowstring down easily. Never "dry fire" (shoot without a projectile) a crossbow for any reason, as this may damage your prod or string. Remember, if you substantially overdraw a bow with a bastard string, you can damage the prod. Still, the bastard string is the safest way to string or unstring your crossbow.

The last way to mount the string is the riskiest, but it requires no assistants, and is workable (for me) up to about 150-pound bows. I have lots of practice with this, so I only occasionally damage a prod this way. To mount a string on a light bow, put the string on one end of the prod. Now put that end of the prod against the ground, near vertical. Put the butt of the stock against your abdomen, or at the intersection of abdomen and leg. Grab the upper limb of the prod with one hand and the free end of the bowstring with the other. Slowly draw back the upper end of the prod while pushing the stock forward with your abdomen to bend the bottom limb of the prod against the ground. When you have enough bend in the prod, you can slip the top end of the string on to the prod.

This trick is easier than it sounds, but kind-of makes a hole in your belly after a few string changes. Caution: it is difficult to see how much you have bent the bottom limb of the prod. It is very easy to over-bend one or the other limb and permanently twist or bend the prod out of square. It will never shoot right again. For a professional shop, and an artisan who is often working alone, this system works pretty well, as its quick and requires no special tools or assistance. I teach all my apprentices how to do string by this method, and most of them find it pretty easy to do after a few tries, but I recommend you only try it if you absolutely MUST change strings right away and can get no help.

String Size Relative to Shaft Size

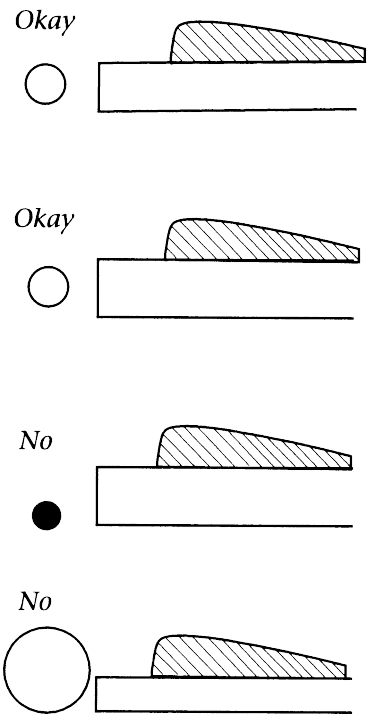

Strings that are less than half the diameter of the shaft tend to under-run the quarrel. Strings that are thicker than the shaft can overrun the quarrel. In both cases, misfire occurs.

Bastard String System

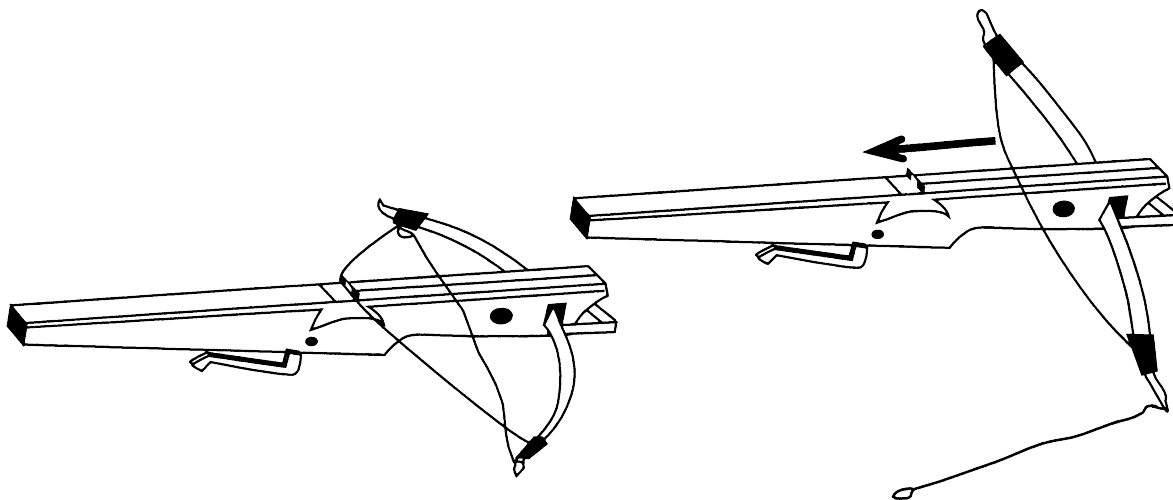

The bastard string and clamp system allows the bow to be strung with minimum effort and minimum possibility of damage.

Stringing the Hard Way

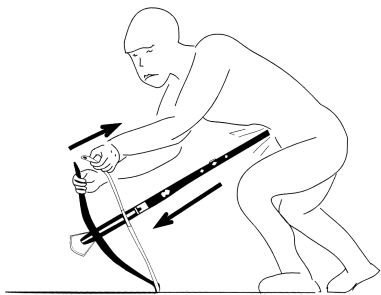

Joe Neandertal must be careful to bend the upper and lower limbs of the crossbow equally.

Characteristics of Rests

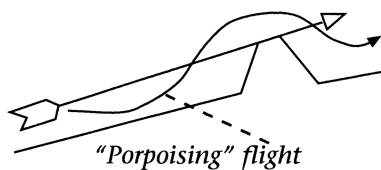

This drawing shows a rest that is too tall. Quarrels will have a porpoising motion when shot from a too-tall rest

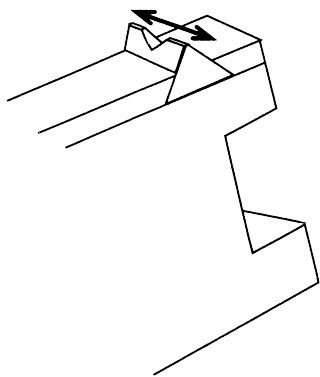

This drawing is of a better quality rest dovetailed into the stock. It is adjustable side-to-side and held in place by a set screw.

Grooves and Rests

Bolt grooves are usually trouble-free and accurate, so long as they are straight and centered, but they cannot be adjusted in any way. Grooves or rests that are off center or warped can cause inaccurate flight, whirling, or misfire. Most western European bows use a full-length quarrel groove. Many central European bows had a simple bone or horn quarrel rest and no groove. Many better-quality medieval crossbows feature a horn or metal-lined groove for lower friction.

Bolt rests can be adjusted if necessary by widening the bolt-notch on one side, or filled on one side by placing a small tack, piece of leather or what have you. Moveable rests that are dovetailed into the top of the stock have a little set screw that keeps them in place. This can be loosened for right-left adjustment. Dove-tailed rests also can be made with two or more grooves of different height so they maybe moved substantially to one side, to lineup a different groove, to change the angle of takeoff. Rests that are too tall may induce a vertical instability (bolt porpoising or pitching up on takeoff) and a raised rest may contribute to misfiring if bolt does not lie correctly on the top (table) of the stock. Though a rest can be moved to account for a slight misalignment of the prod or even stock warpage. If overdone, such adjustment becomes misadjustment and will result in entertaining, if inaccurate, projectile flight. Rests that are too near the stopping point of the bow string sometimes get knocked off the stock, particularly in cases of broken strings, misfires, or dry firing. For this reason, most medieval crossbows mount the rest as far forward as possible. Despite the plethora of problems that a rest can exhibit, it's still a very accurate and efficient way to launch bolts.

The Locks

The most common medieval lock was the single axle roller-nut release. I use this on the vast majority of my bows. It is simple and reliable. The most common sort of problem with locks is misfire. Usually the string hops out of the lock on release and flies right over the butt of the bolt. Sometimes this results in the bolt's leaping in the air, and sometimes the bolt is thrown into the ground.

Crossbows that use a notch and pin primitive lock are commonly subject to misfire as the string hops out of the notch and over the bolt. This can sometimes be reduced by drawing the trigger or push-pin up very slowly, but the most reliable fix is to fit a 'string snubber' over the lock. Snubbers can be fabricated in different ways, but in essence, it's just a little shelf that lies just above the lock-notch. There should be just enough space between the snubber and the table to allow the bolt and string free movement, but not enough for the string to pass entirely over the bolt.

If you think your roller-lock is hopping, a string-snubber isn't going to help much. If you normally shoot with a spring-clip try shooting without it. If you get no misfire without the clip, and misfires with the clip, then you almost certainly have string hop. Hop can be caused by a prod pitched too far forward. If the string at rest lies clear of the top of your stock, you need to adjust your prod. Flying strings are fast but commonly misfire. If your string flies a bit and shoots reliably, congratulations, you've got an efficient bow. Flying strings may be a teeny bit noisy, though.

Occasionally misfire or string-hop can be alleviated by using a thicker string. Ideally the string should push the bolt approximately at the middle of its butt. Occasionally a string may rest too high or low against the fingers of the nut, so it will slip over or under the butt of the bolt. So occasionally string hop can be

alleviated by adjusting the slot between the lugs of the nut.

Often misfires are associated with heavy or slow-turning releases. Brass rollers, though strong and handsome, commonly induce hop. Making a brass or steel nut narrower than horn or plastic ones will reduce the weight, though narrow ones should fit very closely to avoid a rocking oscillation on release. It helps to fit heavy metal rollers in a deeper socket, with less height of lug exposed, and it helps a lot to deepen the string grooves in the backs of the lugs. I might as well note that brass rollers are also the noisiest kind I've ever dealt with. No, I don't really like them very much.

Fine-sanding and lubricating the nut or the shaving sides of the socket can help a sticking lock. DO NOT use graphite. It will make a terrible mess of your bow. Silicone is very slick and non-greasy. Paraffin or beeswax should do nicely. I wouldn't be surprised to discover medieval shooters lubricated with tallow.

One solution to a slow release is to reduce the diameter of their nut and hang it on an axle. By and large this expedient will only temporarily increase speed, as axles bend over time and cause substantial wallowing through the center of the nut. This wear results in a quickly deteriorating standard of release and safety. If the axle is not perfectly centered, rotation will engender very disturbing vibration on release.

Ideally, a roller nut should fit its socket closely, yet turn very freely. As noted above, rollers that fit too tightly will be balky and slow to release. A balky release slows your lock time and quarrel flight. In very high humidity, a tight-fitting lock will occasionally swell, or the stock will swell enough to completely lock up the nut. The most common source of swelling is the spacer plate that fills the space between the nut and side-plate in western-type bows. Solution: sand the spacer plate a bit.

Nuts that fit too loosely run fast but wear quickly and are less accurate. Sometimes such nuts will hop up and try to jam themselves in the top of the socket. The immediate fix for this is to whack the nut with the heel of your hand, but the best long term fix is a new nut, or a reinforce at the back of the socket that will tighten the fit. Don't panic over the occasional jam, but if your bow jams every 100 shots, you ought to fix it. Central European bows that hold the nut in place with several turns of cord can tolerate a looser lock, because the cord dampens the oscillation of the nut, reducing wear to the front edge of the socket and the back edge of the nut. Most western European bows retain the nut with one or two small floating pins that keep the nut in place but do not bear any load.

An old friend owns an ancient German sporting bow that is fitted with loose-fitting horn nut retained by the cord. This bow has the bottom and sides of the nut socket lined on both sides and at the bottom with thin leather. It is possible that this leather was saturated with grease to lubricate the nut. It is also possible that a grease saturated side lining would swell enough to eliminate any side-to-side motion of the nut, thus ensuring maximum accuracy. Should the stock swell at high humidity and temperature, the grease would simply be mashed out of the parchment lining, leaving the nut free to rolls.

Some lock sockets were reinforced with blocks of horn. These blocks reduce wear on front and back edges of the socket and prevent a split or torn back of the socket that sometimes occurs in bows with horn nuts. The horn reinforces are most common on mortised locks, which are made separately and then placed into a rectangular hole in the top of the stock, rather than being cut into the side of the stock. Mortised locks have the potential to be a bit stronger, but are more labor intensive and harder to service. Yes boys and girls, EVERYTHING involves compromise. There are better and worse ways to build crossbows, but every

String-Hop

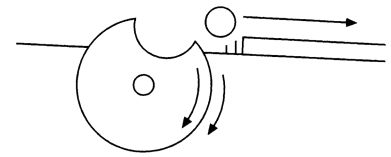

String-hop — when the string misses the butt of the shaft and strikes the quarrel further up causing misfire — is a symptom of several problems.

Fixing String-Hop

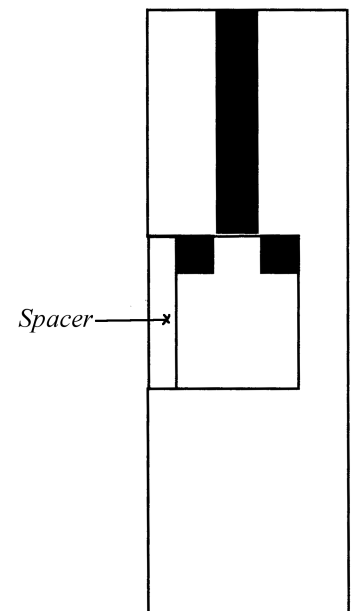

Sanding the spacer plate or the socket of the nut to relieve friction can stop string-hop.

Lock Failure Mode

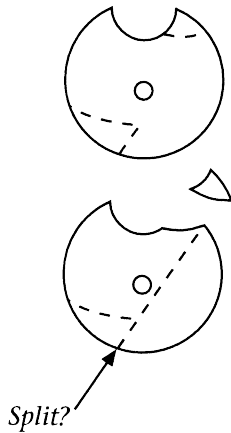

Although lock failure is not common, when locks do fail, it is usually the lugs that chip off

Sear/Trigger Fit

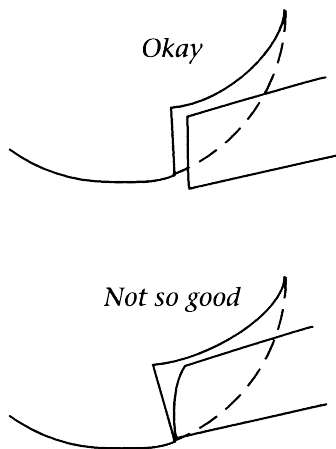

Rounded, worn triggers don't engage the sear properly. Bows in this condition and "go off" accidentally.

decision has consequences- some of them unanticipated.

Lock Failure

Though roller-nuts are normally very reliable, but occasionally they may fail in service. The most common failure is having the back of the nut-socket crack or break away. Usually a broken socket will usually continue to operate under these circumstances, but I don't recommend it.

On a few occasions, I have seen horn nuts fail through the sear axis, particularly when those fitted with a plate-sear. For this reason I now make all my roller-nuts with a sear in the form of threaded steel rod that fits right through the center of the nut top to bottom.

Occasionally I used to make nuts in brass. As noted earlier they are heavier and thus have more tendency to misfire through string-hop. On really strong bows they perform relatively better as strong bows have more power to spare for rotating that massive brass cylinder at high speed. Brass nuts will just about last forever if they are fitted with a hard steel sear plate.

All nuts wear at the sear and at the edge of the rear flat. They also develop a groove around their circumference where the trigger rubs against the surface when the nut is turned. If you are careful to pull your trigger all the way to its stop when shooting and to depress the trigger when rolling the nut over to set it you'll put a lot less wear on the nut. Very strong bows put a lot of wear on the sear and the face of the trigger and they will last longer if you lubricate them. I usually use silicone for this. In the Middle Ages they probably used tallow.

Triggers

Most period triggers were of iron or steel. For many years, I used brass, because its pretty and easy to work. Nowadays I make all my triggers in mild steel. Whatever the material, triggers can become worn down and rounded off at the face. Often heavily worn triggers can be stretched and flattened on the anvil and resurfaced for a clean release. If a trigger can't be stretched enough to resurface, sometimes the sear in the lock can be reworked. Occasionally badly worn triggers must be replaced.

Occasionally the trigger pivot pin on which the trigger hangs will get worn or bent. This damage may cause a change in the operation of the lock as it effectively moves the end of the trigger away from the nut, perhaps 1/32 inch. Trigger pins are easily replaced. Shooters should always have on hand a screwdriver to tighten trigger pins as they can work loose over time. To ensure proper support of the trigger pin, I countersink a nut into each side of the stock. Medieval bows often used substantial inlays of stag horn to achieve the same purpose. Indeed a careful examination of surviving medieval bows suggests that crossbow makers were well aware that they were approaching the structural limits of their stocks, given the numerous and substantial reinforces from end to end.

Spring Clips

Occasionally a spring clip will "cause" misfire problems. If you find your spring clip seems to induce misfires, it probably indicates a marginal misfire problem that only appears when the quarrel is held down. For instance a string-hop

is lifting the quarrel. The spring clip strips the quarrel off the string and the string goes over the quarrel bending the spring clip upward in the process. The real problem is string-hop. The clip is just telling you about it. This particular problem is usually more pronounced on bows with quarrel rests. Generally lowering the quarrel rest, deepening the grooves in the backs of the lugs reducing spring clip tension and modifying the lock timing will solve the problem. Another problem seen in quarrel rest bows is mostly related to the flat surface between the lugs of the nut. If this surface is not level with (or slightly above) the top of the stock WHEN THE NUT IS UNDER LOAD (bow is spanned) the butt of the quarrel will sit in a bit of a hollow. A stiff spring clip can actually lift the lightweight head of a target quarrel right off the rest and cause it to fly quite erratically or even misfire. This wasn't a problem with the heavy quarrels shot from strong medieval bows but it can be a real nuisance on lightweight recreational bows. If the lock is adjusted properly this problem should not arise.

I have no doubt that sufficient reflection could provide further examples of misbehavior in medieval crossbows. The important thing to remember is that most problems are fairly easily identified and remedied with a bit of observation and reflection. How tough can it be ? There are only three moving parts and a spring.

String Overruns Quarrel

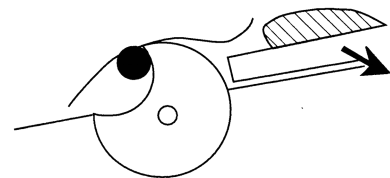

Sometimes the spring clip appears to cause the string to overrun the quarrel. The problem is not the spring clip, but string-hop.

Unlevelness Between Lugs

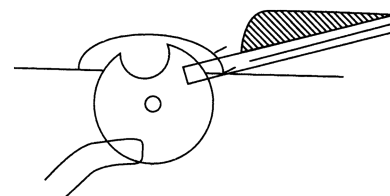

If the surface between the lugs of the nut is not level and even with (or slightly above) the table, the pressure of the spring clip forces the butt of the shaft into the hollow, leaving the head of the quarrel.

WHERE DO WE GO FROM HERE?

As of this writing I am still struggling to relearn an ancient trade. In the future I hope to be able to purchase more of the parts I now fabricate myself from artisans who can do it better. It is already possible for me to get nice bronze sights, steel prods, and steel bow irons, all of a better quality than I can produce. A widening market should mean more authentic bows at lower prices. Several people are experimenting with horn-and-sinew composite prods. Eventually, a few of those maybe available but I do not anticipate their ever being available at less than exorbitant prices. Five-thousand dollar prods anyone?

I am experimenting with more sophisticated locks (more expensive of course) and using more bone and horn inlay in place of Micarta. Someday I hope to replace Micarta entirely with horn and bone, though that's almost certain to result in much higher cost. Certainly, I still have a lot to learn about very sophisticated inleting and interlocking horn parts on powerful German 15th and 16th century crossbows. The more you know, the more you need to know.

The most important elements in making these bows look and operate correctly are research and hands-on experimentation. You can't do it right if you don't know what its supposed to look and work like. You can bypass a lot of problems if you try to replicate the original as closely as possible. Everything was done as it was for a reason. You can't intelligently make changes or materials substitutions if you don't understand why things were done as they were. It always tickles me to find wear on original bows in precisely the same places that I have problems on mine, and I have discovered many important lessons by thinking of a "better, easier" way than the original. These detours usually tell you precisely why they didn't do it that way.

I take every available opportunity to photograph sketch or handle original crossbows in museums. Of course you want to make sure to get permission to photograph if there's any question, but it is surprisingly easy to get permission to photograph or to handle if you are willing to give some advanced warning, and don't behave like a know it all. The sad truth is that most Americans don't give a fig for history; theirs or anybody else's, and hence most scholars are eager to share their knowledge and resources.

If you wanna know ancient crossbows, go to museums. No book or set of drawings will inform you half so well as five minutes with the real McCoy. The next best thing is pictures from every angle. Most books and catalogs show crossbows from directly above which will give you a general idea what crossbows look like but won't tell you much about details of shaping and construction. So the first thing to do is to go to your nearest great museum. Regional museums may have an interesting piece or two but be aware that their information about the single piece on display may be fragmentary or incorrect. Great museums can usually afford to employ at least one arms expert who is generally knowledgeable about the articles on display. In North America I can recommend: The Metropolitan Museum, Royal Ontario Museum, Higgins Armory, Los Angeles Museum, Chicago Museum of Art, among others. In Europe there are many fine collections, with many excellent bows and associated equipment. I have personally visited the Tower of London, (before the armory moved to Leeds) The Wallace Collection and the Victoria and Albert Museum in England, as well as the Kunsthistorisches Museum in Vienna and the Landeshut Museum in Graz, Austria. If you're really interested in this subject, make a pilgrimage to the good sources.

Every year I try to devise ways to make my bows a little more authentic. The trick is to do this without making them more expensive. This increase in

authenticity is made a little easier by the fact that the more bows I do, the more efficient I become. I can add details today that I could not have afforded time-wise a few years ago without substantially adding to price. Years ago I usually bolted on stirrups since that was very easy and secure. The first few stirrups I lashed on, as was common medieval practice, worked loose quickly and cut the bow bindings as well. Today, I don't bolt on stirrups unless they are specifically requested and my tied stirrups stay put. I have learned how to do this simple feature correctly and it's now no more trouble than bolting on. Mostly I needed practice and experience. I have never claimed to be particularly innovative talented or motivated to try new systems but if you practice enough you learn in spite of yourself.

Many fine details of medieval construction and decoration simply cannot be replicated without extra expense. Some elements, like all steel metalwork in place of shiny brass, have required a certain amount of customer education. I discovered early on that brass sold much better than steel, even though medieval bows seldom show any brass or bronze work. (I have seen 15th or 16th century Spanish crossbow remains with bronze lock plates and one authentic example of a brass or bronze nut) Twenty years ago I got very few requests for steel triggers and lockplates. Now I work steel all the time. Why? Because my customers have become more sophisticated about crossbows.

There does seem to be a limit to what people are willing to pay for off-the-rack bows. Most people would rather order something specific to their tastes if the price much exceeds \$350. For this reason even for a very large medieval fair like Pennsic War I send few bows over that price and I expect most of those I do bring in the \$350 or more range will be bows for display.

So what does the future hold for the crossbow business? I hope some day to return to Europe to see more of the great collections. With some good luck and preparation perhaps I can talk with some of the noted European arms experts to see what new insights I can glean from scholars who have dealt directly with the old bows for years. Perhaps someday I will be ready to do the *Big Book of Crossbows*, but given the length of time this volume has required that could take a while. That book would I hope have lots of photos of many different types and styles of crossbows from all over Europe. The pictures would be from a standard set of angles against a standard grid so you could get a good sense of scale and proportion right from the photos. We'll see if that ever comes to pass. It would please me greatly to do that. Ah well, all in good time...

BIBLIOGRAPHY

- Alm, Josef. *European Crossbows. A Survey by Josef Alm*. Translated by H. Bartlett Wells. Trustees of the Royal Armouries and the Arms and Armour society. London 1994. ISBN 0-948092-20-3. This important work was originally published by the noted Swedish arms historian Josef Alm in 1947. This is the first English translation. This book contains much original research on Scandinavian crossbows in particular that is nowhere else reproduced. The volume is well illustrated with photos of crossbows diagrams and reproductions of period pictures. A "must have" for the library of the serious crossbow enthusiast.
- Bilson, Frank. *Crossbows*. Hippocrene Books. N.Y., N.Y. 1974 & 1983. ISBN 0-88254-701-1. This is a reasonably priced and generally obtainable book, mostly devoted to modern crossbows and target shooting. Generally a solid source though he has a few strange ideas...
- Bradbury, Jim. *The Medieval Archer*. St. Martin's Press New York, N.Y. 1985. ISBN 0-312-52665-2. This is an interesting account of the archer in combat in the middle ages. It is primarily concerned with the British archer but has useful comments on the use and effectiveness of archery in combat.
- Harmuth, Egon. *Die Armbrust, Ein Handbuch*. ADEVA press. Graz, Austria 1986. ISBN 3-201-01298-X. This is the new standard work on medieval crossbows particularly central European crossbows. Those who toss this one off as a rehash of Payne-Gallwey's book haven't looked at it. This volume is worth the \$30 or so just for the illustrations and radiographs of medieval bows. Presently it is available in German only.
- Heer, Eugen. "Notes on the Crossbow in Switzerland," *Arms and Armor Annual* volume 1, Follett Publishing: Chicago, 1973, pp. 56-65. ISBN 0-695-80407-3. Eugen Heer is a recognized Swiss arms-and-armor expert. The article is very informative, if brief, and well illustrated.
- Heer, Eugen. *Die Armbrust Eine Sportwaffe*. Verlag Schlapfer & Co. AG: Herisau/Trogen, 1976. This is a nice little volume dedicated mostly to the celebration of Swiss target shooting. The first 31 pages treat with the history of the crossbow, with many beautiful illustrations and photos.
- Paterson, William F. *A Guide To The Crossbow*. Society of Archer Antiquaries, 1990, no ISBN. This volume is a limited edition memorial publication of the collected notes on the crossbow of W. F. Paterson, for many years one of the leading lights of the society of Archer Antiquaries. The text is informative provides useful detail on a number of remote points of crossbow lore and has many useful diagrams and illustrations. For my money this book stands right next to Harmuth's book for value and it is written in English, reason enough for any of us monoglot readers. If you want this one, try a web search for Manchester University Museum, and go to Simon Archery Collection, books.
- Payne-Gallwey sir Ralph Bt. *The Crossbow*. Holland Press: London, Second Edition, 1958. ISBN 0-946323-14-3. This book has long been the standard English language work on the crossbow. By and large it stands the test of time, though Egon Harmuth's book must be considered more

authoritative. Beware: if Payne-Gallwey wasn't sure of a point, like many Edwardian authors, he would make up something. At least in his case these fabrications usually work.

Sensfelder, Jens, *Crossbows in the Royal Netherlands Army Museum*. Eburon Academic Publishers, 2007, Delft, Netherlands. ISBN 978-90-5972-174-6. This is a lovely book in large format, with many photos and dimensions of bows in the Netherlands Army collection. A beautiful, detailed work, indispensable to those who want to know the details of Medieval crossbows.

Stevens, George. *The Crossbow, From Thirty-Five Years with the Weapon*. *Desert Publications: Cornville, AZ, 1980*. ISBN 0-87947-081-X. Stevens was an American pioneer in the revival of the crossbow from obscurity to a popular sporting weapon. Crossbow fans in America owe him a debt of gratitude. His book is small, affordable, and very useful. It is also rather poorly laid out. This book is one to have, just try to ignore the strange appearance.

Wilson G. M. *Crossbows, from Treasures of the Tower*. Her Majesty's Stationery Office, London, 1976. ISBN 0-41-670445-4. This book is a pamphlet in the Treasures of the Tower Series. These little monographs are usually cheap and authoritative. Very nice illustrations and informative text.

